

MODEL

SuperNova MKVI

www.earthquakesound.com



**Class "J" Powered
Subwoofer
600WRMS**

U S E R M A N U A L



Congratulations and thank you for choosing the new Earthquake SuperNova MKVI Subwoofer as a key component for your audiophile system. The MKVI subwoofers are designed to meet the highest standards of performance and sound quality. In addition, Earthquake Sound's IQ certification and patented Class "J" circuitry ensure that the subwoofer meets and exceeds all industry standards. The new MKVI subs include many unique technologies that allow them to deliver "World Class" performance, even under extreme operating conditions.

The SuperNova's are ruggedly constructed high quality audiophile subwoofers. The Digital feedback class "J" Circuitry, allows the subs' built-in amplifier to produce massive amounts of power with minimal heat production. This patented circuitry delivers high efficiency in the range of 99% -- the typical class AB amplifier runs at about 40 to 50%.

The MKVIs' amplifier offers a room correction technique that surpasses all previous attempts. The intelligent "Back emf" drive circuit interacts with the subwoofer design and memorizes system tuning frequencies as well as system type. The information, which is stored in microprocessor, turns on a preset group delay curve that serves as a correction reference. This information deals only with time correction that moves the peaks and the dips in a room to a flat. Once that is achieved, the user will resort to the final correction- EQ the room. For that reason, Earthquake's SuperNova MKVI is truly an intelligent system. 20Hz, 30Hz and 40Hz frequencies can be cut or boosted by a whopping 6dB, these corrections help in producing wider range of listening position that is unprecedented for the room.

| <u>SOUND LEVEL</u> <u>DBA</u> | <u>DURATION</u> <u>IN HOURS</u> |
|----------------------------------|------------------------------------|
| 90 | 8 |
| 92 | 6 |
| 95 | 4 |
| 97 | 3 |
| 100 | 2 |
| 102 | 1 - 1 1/2 |
| 105 | 1 |
| 110 | 1/2 |
| 115 | 1/4 or less |

*THE CHART (ON THE SIDE) SHOWS THE U.S. GOVERNMENTS
OCCUPATIONAL SAFETY AND HEALTH ADMINISTRATION (OSHA)
REGULATIONS WHICH WERE IN EFFECT AT THE TIME OF THIS
PUBLICATION FOR PERMISSIBLE NOISE EXPOSURE,
PER 29CFR1910.95, TABLE G-16.*

CAUTION: The SuperNova MKVI is capable of generating high sound pressure levels. You should exercise caution when operating this system. Long term exposure to high levels of sound pressure will cause permanent damage to your hearing. Sound pressure levels exceeding 85dB can be dangerous with constant exposure. Set your audio system to a comfortable loudness level. Earthquake Sound Corporation does not assume liability for damages resulting from the direct use of the MKVI, and urges users to play the MKVI at moderate listening levels.

ITEMIZED LIST OF INCLUDED ITEMS:

1. One (1) AC Power Cable
2. One (1) Owners' Manual
3. One (1) Registration Card
4. One (1) Remote Control
5. One (1) SuperNova Subwoofer

When you have safely removed the subwoofer from the packaging and placed it in a safe area, perform a thorough physical inspection and report any damage to the dealer that you purchased the unit from. We suggest that you keep the original packaging, and that it should be stored in a safe, dry place in case you're required to transport the unit. The customized packaging is specially designed to protect the amplifier from potential damage that can arise when shipping such a product.

WARNING!

To reduce the risk of fire or electric shock, do not expose this product to rain or moisture. Do not attempt to “lift the ground” by removing the ground pin from the AC cable. Make sure that your household electrical wiring supports proper AC grounding techniques before plugging in this product. Keep the heat sinks and top cover free of dust to allow for proper heat dissipation. Never expose this product to extreme temperature. Always connect the audio signal path cable prior to connecting the AC mains.

CAUTION!

No user-serviceable parts inside. Do not attempt to remove cover or repair this product, as severe electrical shock may result and it may disrupt your warranty.

IMPORTANT!

Make sure that your local AC voltage complies with the unit's label. Damage caused by plugging this subwoofer into an AC receptacle of the wrong voltage will not be covered by warranty.

Unpacking Your Supernova

The Supernova is double boxed for product safety. We highly suggest having a padded surface and at least two (2) people to safely unpack the Supernova.



Step 1

On a padded surface, carefully place the box on its side to remove the bottom packing tape and staples.



Step 2

Without tilting the box too much, tug the bottom flaps outward and keep the protective foam in place.



Step 3

Gently reposition the box upright.



Step 4

Slide the box off, minding the protective foam on the top, bottom, and sides of the subwoofer.

Why having two gains on a mono subwoofer is a good thing?

Often you hear the term “subwoofers are non-directional”; this is not true. Subwoofer placement is harder to pick when two low frequencies are crossed. The wider the room, the more directional the subwoofer. The easiest solution is to use two subwoofers in the front: one on the left and a second on the right. The signal to both is mono. In some applications, users might have small front speakers or planar speakers. Both speakers have an early roll off in the sub-harmonics. The planar needs help from 150Hz on down, having two front subwoofers placed on the left and the right is a healthy solution to this problem.

Two Subs

While having two subwoofers is better than one, the MONO signal that drives these subwoofer keeps them from projecting the three dimensional images in the sub-harmonics. The use of two subwoofers allows you to cross the subs up to 150Hz sound quality, imaging and staging. The two-front-subwoofer-system is an excellent solution to planar speaker’s low frequency response early roll off. When locating these subwoofers in a close proximity to the stereo satellite, the subs will enhance low frequency extension. It will be better to have a stereo subwoofer to help in the lower bass notes and their placement.

If a bass Guitar player was standing on the left side of the stage and he played an EE note (42Hz), then the right sub will also respond to that and create havoc on the stage. In fact, if you only have one single sub in the room and it’s placed on the right side of the room, while the bass guitar player is playing his music on the left side of the stage. As soon as he hits the EE note, the sub speaks out on the right and completely destroys the stage. To give you three-dimensional front-end bass that allows you to have a low frequency dynamic stage, Earthquake designed dual input circuits that use buffers to maintain your stereo separation on the processor side while mixing stereo front signals to produce 3D bass.

GOOD / This illustration shows a single subwoofer setup

The blue arrow represents the subharmonic frequencies as they move always toward the sub in the single sub system. The red arrow represents the lows + mids + highs as they follow the action.

Note: The breakaway and the image separation. best response when blue and the red are identical.

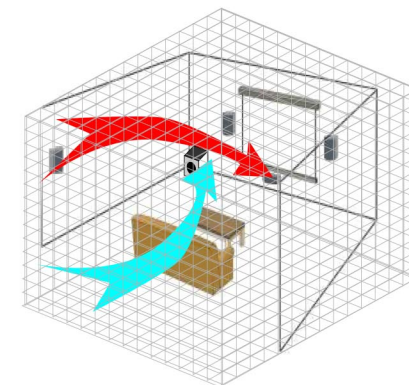

BETTER / This illustration shows dual subwoofer with mono signal

The blue arrow represents the sub-harmonic frequencies as they move always toward the middle in a mono-two-subs- system. The red arrow represent the lows+ the mids+ highs as they follow the action,

Note: the breakaway and the image separation.

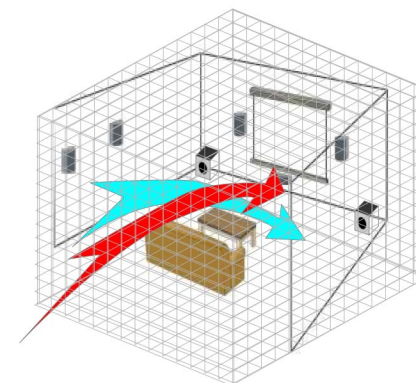

BEST / This illustration shows dual subwoofers with stereo+mono signals

In this illustration, the stereo subwoofers keep the sub-harmonics dynamically synchronized in motion with the rest of the audio systems. Fully complementing the sub-harmonics for mids and the highs

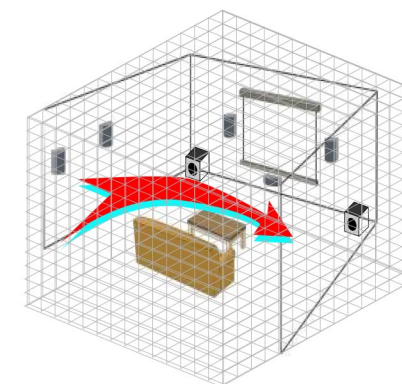

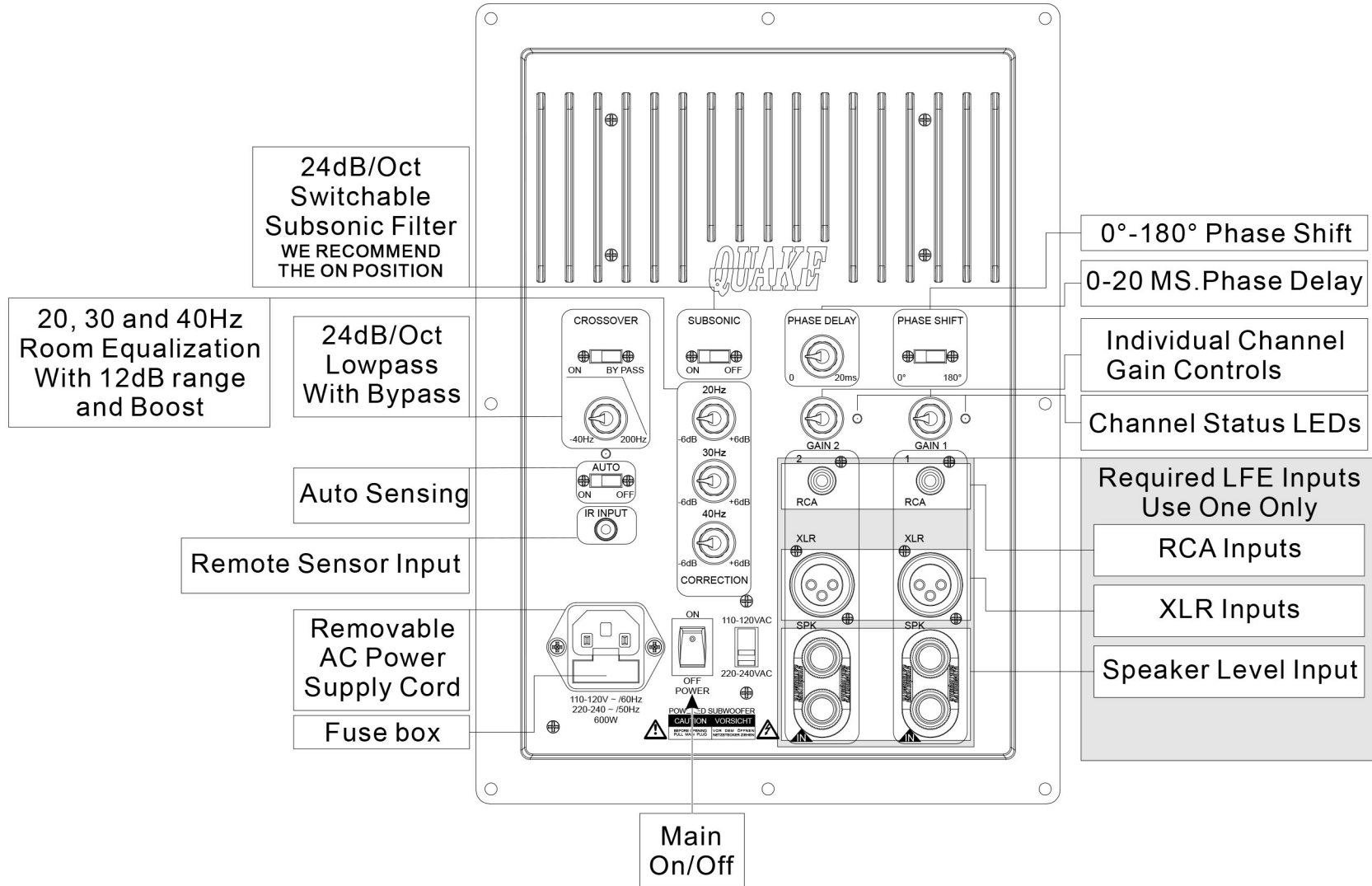

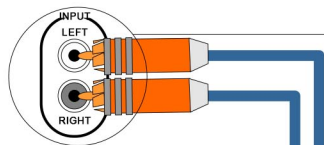

Split L/R RCA's To Amplifier's LEFT/RIGHT Channels.

The back side of a typical processor or receiver

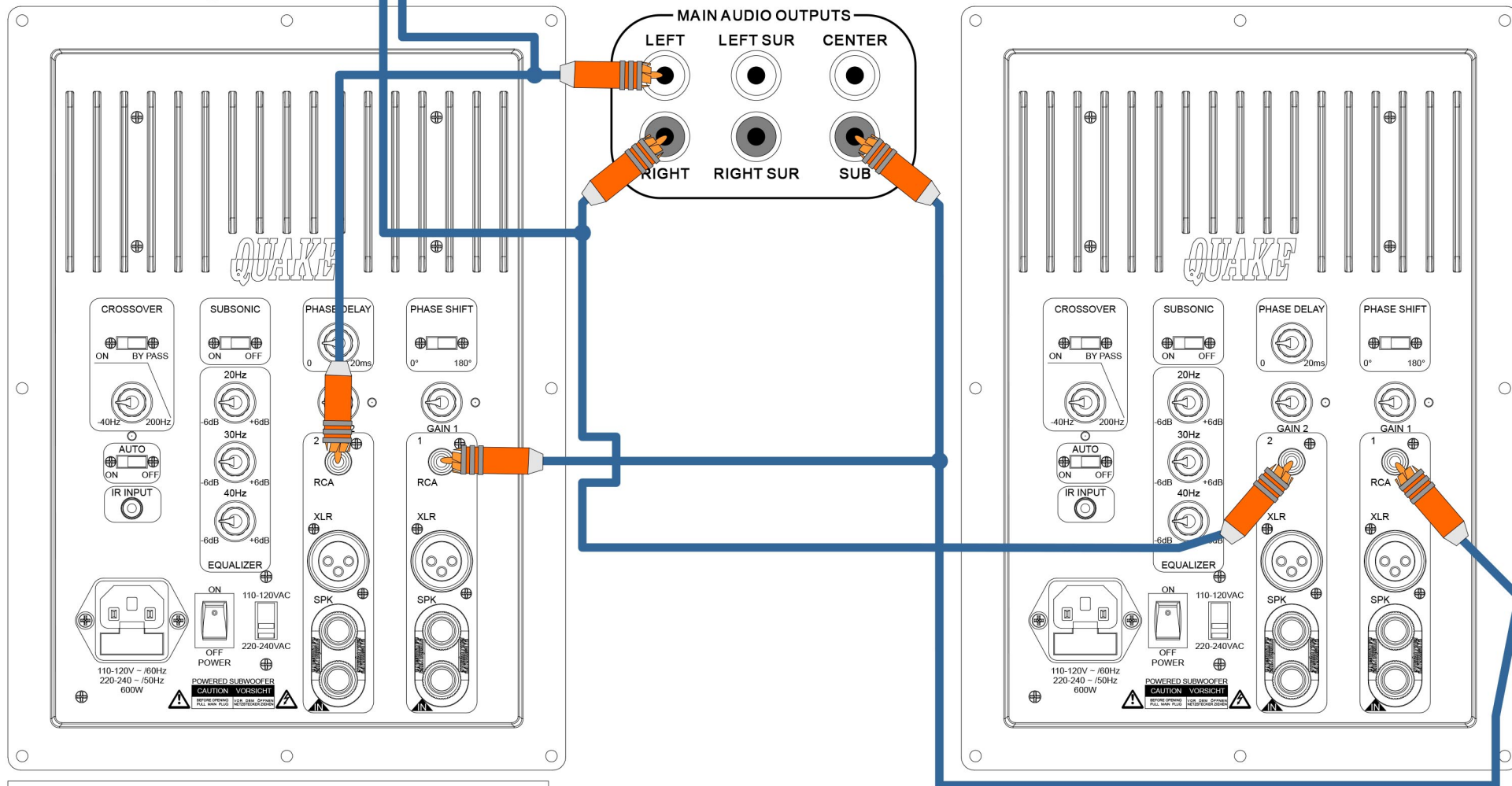

The same wiring configuration can be duplicated for the XLR inputs. NOTE: We provide three different input types, but do not recommend mixing input types.

The back side of a typical processor or receiver

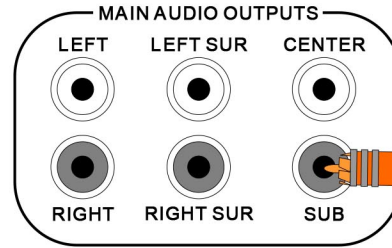

Usually one RCA has enough signal to drive the IQ amplifier to its full output. However, in some cases where signal is too low for the IQ amp to produce its full output, you may use a "Y" connector to increase the amp's sensitivity.

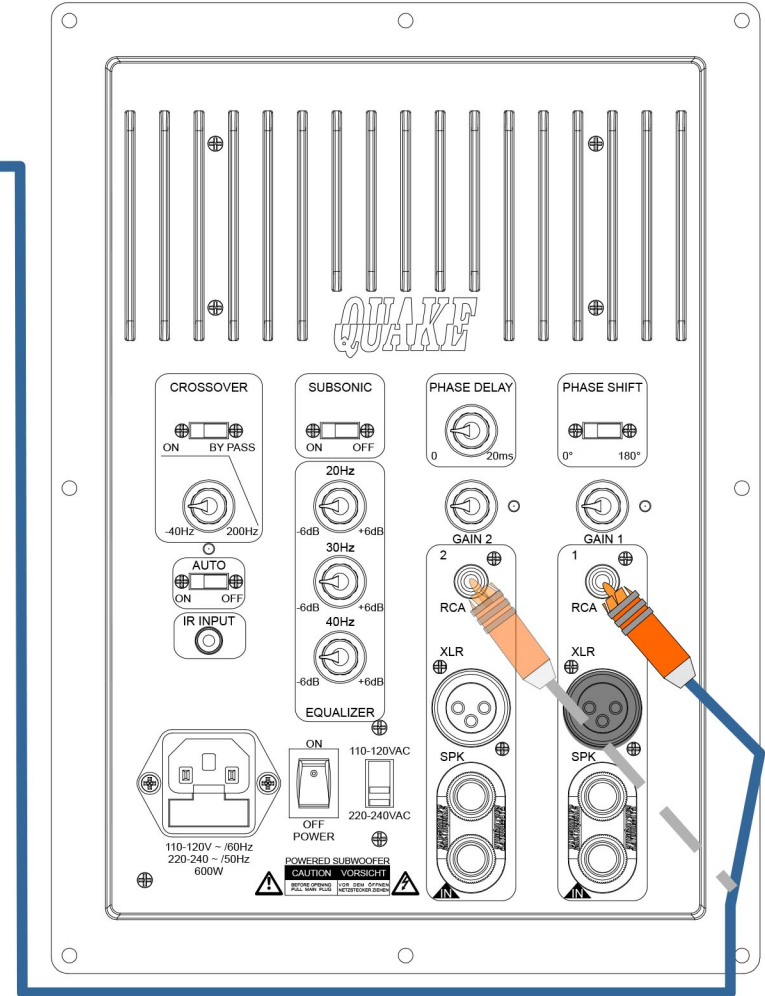

The MKVIs' amplifier offers a room correction technique that surpasses all previous attempts. The intelligent "Back emf" drive circuit interacts with the subwoofer design and memorizes system tuning frequencies as well as system type. The information, which is stored in microprocessor, turns on a preset group delay curve that serves as a correction reference. This information deals only with time correction that moves the peaks and the dips in a room to a flat. Once that is achieved, the user will resort to the final correction- EQ the room. For that reason, Earthquake's SuperNova MKVI is truly an intelligent system. 20Hz, 30Hz and 40Hz frequencies can be cut or boosted by a whopping 6dB, these corrections help in producing wider range of listening position that is unprecedented for the room.

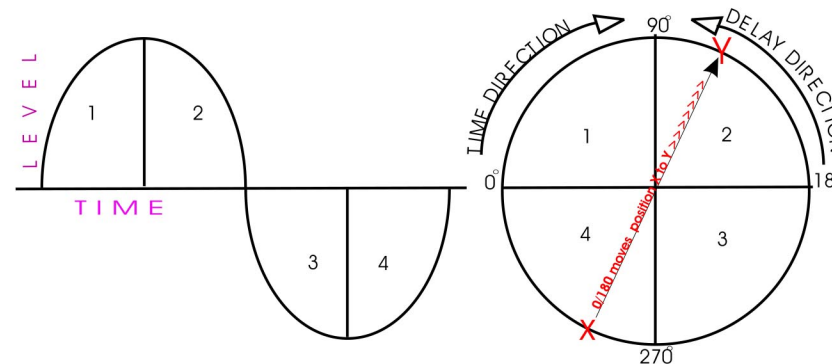

To begin the process of room correction, you should have two people: One person will make adjustments at the amplifier and the other at the meter.

STEP 1: Place your subwoofer in the most desirable area.

STEP 2: Have the second person sit on a chair or sofa with a testing microphone or SPL meter.

STEP 3: Load "white Noise" CD or 50Hz tone continuous.

STEP 4: With the amp phase at 0° and the delay set at 0°, measure the SPL.

STEP 5: Rotate variable delay until the dB measurement peaks (you will know that it has peaked when the measurement begins to go back down). Rotate the knob back to the peak section.

STEP 6: Measure angle of rotation in approximate degrees.

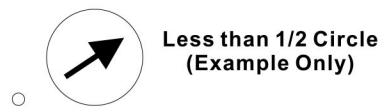

STEP 7: Reset all adjustments to zero(0) / Flip phase switch to 180° and redo test.

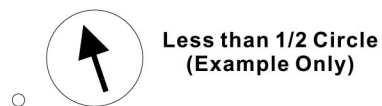

STEP 8: Your best setting is when the phase is at 180° and there is less delay.

When setting the room EQ, do not over power the speakers. As this may cause them to bottom out or cause other more severe problems that your warranty will not cover. To set up the room EQ, you will need a spectrum-analyzer, or you can use the rule of thumb.

@ 20Hz apply a 3/4 turn (use caution)



@ 30Hz apply a 1/2 turn



@ 40Hz apply a 1/4 turn



| MODEL | | MKVI-12PIANO / BLK | MKVI-15PIANO / BLK | | |
|---|---------------------------------|---|------------------------------------|----------------------|-----------------------|
| Description | | Sealed Enclosure With Patented Passive Radiator Technology | | | |
| Dimensions (HxWxD) | | 16 1/4" x 15 1/2" x 19 1/2" | 17 3/4" x 17" x 21" | | |
| Weight | | 73 Lbs. | 86 Lbs. | | |
| Frequency Response | Subsonic ON Crossover at MAX | 16Hz-130Hz | 15Hz-120Hz | | |
| Frequency Range 40/200Hz adjustable | Subsonic ON | -24dB/Oct @ below 17Hz | -24dB/Oct @ below 15Hz | | |
| | Subsonic OFF | 120dB @ 10Hz | 123dB @ 10Hz | | |
| Bass Unit | | 12" Cast Aluminum With Flat Piston | 15" Cast Aluminum With Flat Piston | | |
| Passive Radiator | | 12" Patented Design | 15" Patented Design | | |
| Finish | | Multi Layer Piano Black Lacquer or Real Black Ash Wood Veneer | | | |
| Subwoofer Amplifier | | <p>Description: Type: Class "J" Power Output: 600 Watts RMS Input Impedance: 18 kOhm (RCA) Signal to Noise Ratio: > 106dB (balanced) 105dB (unbalanced) @ rated power</p> <p>Inputs: XLR / RCA, High-level Functions: Power, Room equalization, Subsonic filter, Phase shift, Phase Delay, Lowpass/Bypass, Channel and power status LEDs, Dual gains internally mixed, Music sensing Power ON/OFF, Remote control w/ mute.</p> | | | |
| Power Line Voltage | | 110 Volts / 240 Volts AC Select Input | | | |
| Minimum Required Signal For Full Output Gain and Crossover @ MAX | | One(1) RCA 105 mV | Two(2) RCAs' 50 mV | One(1) XLR 210 mV | Speaker Line 2.4 V |
| Current Draw | Auto OFF | .08 Amp (115V) | | | |
| | Auto ON | .17 Amp (115V) | | | |
| | Full Output | 7.6 Amp (115V) | | | |

Earthquake warrants the original purchaser that all Factory Sealed New Audio Products be free from defects in material and workmanship, under normal and proper use, for a period of five (5) years from the date of purchase (as shown on the original bill of sale with serial number affixed/written on it). The five (5) years warranty period is valid only if the product is properly installed by an Earthquake authorized party, and the warranty registration card is properly filled out and sent to Earthquake Sound Corporation. If the product is installed by a non-authorized party, a ninety (90) days warranty period applies.

(A) Five (5) years limited warranty plan coverage guidelines:

- First year: Earthquake pays for labor, parts, and ground freight (only in US mainland, not including Alaska and Hawaii) back to customer.
- Second year: Earthquake pays for labor and parts only, customer must pay freight both ways.
- Third, fourth & fifth year: Earthquake pays labor only. Customer must pay for parts and freight both ways.

(B) Warning:

Products (sent for repair) that are tested by Earthquake technicians and deemed to have no problem, will not be covered by the five (5) years limited warranty. Customer will be charged a minimum of one (1) hour of labor (ongoing rates) plus shipping charges back to customer.

(C) Earthquake agrees to repair or replace - at our option - all such defective products/parts subject to the following provisions:

- Defective products/parts have not been altered or repaired by other than an Earthquake factory approved technician.
- Products/parts are not subjected to negligence, misuse, improper use, or accident, damaged by improper line voltage, used with incompatible products, or have its serial number or any part of it altered, defaced or removed, or have been used in any way that is contrary to Earthquake's written instructions.

(D) Warranty Limitations:

Earthquake warranty does not cover products that have been modified or abused. Including but not limited to the following:

- Damages to speaker cabinet and cabinet finish due to misuse, abuse, or use of improper cleaning materials/methods.

- Bent speaker frame, broken speaker connectors, holes in speaker cone, surround & dust cap, burnt speaker voice coil.
- Fading, deterioration of speaker components & finish due to improper exposure to elements.
- Bent amplifier casing, damaged finish on the casing due to abuse, misuse, or improper use of cleaning material.
- Burnt tracers on PCB.
- Product/part damaged due to poor packaging or abusive shipping conditions.
- Subsequent damage to other products.

A warranty claim will not be valid if the warranty registration card is not properly filled & returned to Earthquake with a copy of the sales invoice.

(E) Service Request:

To receive product/s service, contact Earthquake service department at (510) 732-1000 and request an RMA number (Return Material Authorization), items shipped without a valid RMA number will be refused. Make sure you provide us with your complete/correct shipping address, a valid phone number, and a brief description of the problem you are experiencing with the product. In most cases, our technicians might be able to resolve the problem over the phone, thus eliminating the need to ship the product.

(F) Shipping Instructions:

Product/s must be packaged in its original protective box/es to minimize transport damage and to avoid repackaging fees. Shipper claims regarding items damaged in transit must be presented to carrier. Earthquake Sound Corporation reserves the right to refuse product improperly packed. Original bill of sale must accompany product returned for service. We encourage you to include with the package a written description of the problem. Ship product to: Earthquake Sound Corp. 2727 Mc Cone Avenue, Hayward, CA 94545. Ph (510) 732-1000. You are responsible for the cost of shipping the product to Earthquake Sound Corporation.

(G) Disputes Resolution:

All disputes - between clients and Earthquake Sound Corporation - resulting from the five (5) years limited warranty policy must be resolved according to the laws & regulations of the county of Alameda -California.

| <u>SOUND LEVEL</u> <u>DBA</u> | <u>DURATION</u> <u>IN HOURS</u> |
|----------------------------------|------------------------------------|
| 90 | 8 |
| 92 | 6 |
| 95 | 4 |
| 97 | 3 |
| 100 | 2 |
| 102 | 1 - 1 1/2 |
| 105 | 1 |
| 110 | 1/2 |
| 115 | 1/4 or less |

THE CHART (ON THE SIDE) SHOWS THE U.S. GOVERNMENTS
OCCUPATIONAL SAFETY AND HEALTH ADMINISTRATION (OSHA)
REGULATIONS WHICH WERE IN EFFECT AT THE TIME OF THIS
PUBLICATION FOR PERMISSIBLE NOISE EXPOSURE.
PER 29CFR1910.95, TABLE G-16.

CAUTION: The SuperNova MKVI is capable of generating high sound pressure levels. You should exercise caution when operating this system. Long term exposure to high levels of sound pressure will cause permanent damage to your hearing. Sound pressure levels exceeding 85dB can be dangerous with constant exposure. Set your audio system to a comfortable loudness level. Earthquake Sound Corporation does not assume liability for damages resulting from the direct use of the MKVI, and urges users to play the MKVI at moderate listening levels.



Sound That Will Move You.