

1.INPUT/输入特性

1.1 Input voltage rating/额定输入电压范围:	100-240V AC	Code 33774382
1.2 Input voltage range/输入电压范围:	90-264V AC	
1.3 Input frequency rating/额定输入频率:	60/50 Hz	
1.4 Input frequency range/输入频率范围:	63/47 Hz	
1.5 AC input current/最大输入电流:	0.75 A Max .@100V AC	
1.6 AC input power saving/输入空载功率:	0.075 W Max .@230V AC at no load	
1.7 Inrush Current/最大浪涌电流:	30 A Max .@100VAC (Cold start/冷启动)	
	60 A Max .@230VAC (Cold start/冷启动)	
1.8 Leakage current/最大漏电流:	0.25mA Max	

2. Output characteristics/输出特性

2.1 Output voltage/输出电压:	5 V
2.2 Max. load current/最大负载电流:	4 A
2.3 Min. load current/最小负载电流:	0 A
2.4 Output no-load voltage/输出空载电压:	5 V± 8%
2.5 Output full load voltage/输出满载电压:	5 V± 8%
2.6 Output ripple & noise/输出纹波与噪声:	300 mV max.

Note: 1. output voltages shall be measured at output connector.

2. Ripple measurements shall be made with an oscilloscope of at least 20 MHz bandwidth. Output shall be bypassed at the connector with a 0.1uF ceramic disk capacitor and a 10uF electrolytic capacitor to simulate system loading at temperature 25°C

1.输出电压要求测试连接输出端。

2.纹波测试要求在环境温度25度情况下示波器频宽在20MHz以下，量测输出连接端并联一个10uF电解电容与0.1uF的独石电容。

3. General characteristics/一般特性

3.1 Total output power/额定总输出功率:	20 Watts
3.2 Average Efficiency / 平均效率:	While input 115Vac and 230Vac, the average efficiency is more than 83.68%. The test point is at 10%, 25%, 50%, 75% and 100% load after 30 min warm up at max load. comply must with requirements level VI 在输入115Vac和230Vac条件下，平均效率不小于 83.68% 测试点分别是最大载的10%、25%、50%、75%和100%。测试要求电源满载预热30分钟测试。必需符合能效六等级要求。
3.3 Short circuit protection/短路保护:	A Short circuit placed on DC output shall cause no damage or auto-recovery the power supply. 输出短路时电源不会损坏或自动还原供电。
3.4 Over Voltage Protection/过压保护:	When overvoltage occurs on DC output shall cause no damage or auto-recovery the power supply. 输出过压发生时电源不会损坏或自动还原供电。

4. Environment/环境:

4.1 Operating temperature/:操作温度	0~40°C
4.2 Storage temperature/:存储温度	-25°C to 85°C
4.3 Operating humidity/:环境湿度	8% to 90%
4.4 Storage humidity/:存储湿度	5% to 95%

5. Application safety standard : meet/应用安全标准

<input type="checkbox"/> UL 60950	<input type="checkbox"/> EN 60950	<input checked="" type="checkbox"/> AS/NZS 60950	<input type="checkbox"/> J60950	<input type="checkbox"/> K60950
<input type="checkbox"/> UL 60065	<input type="checkbox"/> EN 60065	<input type="checkbox"/> AS/NZS 60065	<input type="checkbox"/> J60065	<input type="checkbox"/> Brazil
<input type="checkbox"/> UL 1310	<input type="checkbox"/> EN 60335	<input type="checkbox"/> GB4943	<input type="checkbox"/> J61558	
	<input type="checkbox"/> EN 61558	<input type="checkbox"/> GB8898		

6. EMC standard /电磁干扰标准:

6.1 EMI standard / EMI 标准:

<input type="checkbox"/> FCC Part 15 Class B : 2008	<input type="checkbox"/> GB 9254-2008	<input type="checkbox"/> J55022
<input checked="" type="checkbox"/> EN 55022: 2010+AC:2011	<input type="checkbox"/> GB 17625.1-2012	<input type="checkbox"/> J55013
<input type="checkbox"/> EN 55013: 2013		

6.2 EMS standard / EMS 标准:

<input checked="" type="checkbox"/> EN 61000-4-2/ESD静电耐受测试	<input checked="" type="checkbox"/> EN 61000-4-5/Surge点击波耐受测试
<input checked="" type="checkbox"/> EN 61000-4-3/RS辐射场强耐受测试	<input checked="" type="checkbox"/> EN 61000-4-6/CS传导场强耐受测试
<input checked="" type="checkbox"/> EN 61000-4-4/EFT/Burst瞬间脉冲耐受测试	

7. HI-POT test/高压测试

(1)Primary to secondary/:初级对次级	4525VDC for 3sec. 5mA(production testing)
	4242VDC for 1min. 5mA(Sample testing)
(2)Primary to case/:初级对外壳 (only for metal case)只适用于金属外壳	4525VDC for 3sec 5mA(Production test)

8. Insulation resistance /绝缘电阻

Input to output/输入对输出:	>10Mohm.@500VDC
------------------------	-----------------

9. Reliability:/ 可靠性

9.1 MTBF/平均故障间隔时间:	50K hours min. @full load at 25°C ambient temperature.
--------------------	--

9.2 Burn-in/烘烤:	2-4hours,25~45°C ,Input 220VAC,Output 80% load.
-----------------	---

9.3 Altitude: Will operate properly at altitude between 0 to 6000ft

正常运转在0到6000英尺之间的高度.

10. Mechanical/ 机械结构

10.1 Dimensions/尺寸:Please see the mechanical dimension drawing./请参见机械尺寸图

10.2 Weight/重量: _____ g

11. Mechanical specification/机械参数:

11.1 Drop test/落地测试: The height of 1 M,frequency 1 drop per face.

dropping surface on concrete floor judgment standard:No function fail & no cabinet joint broken.

11.2 Bending test: With load 200g, then bend ± 60 degree at ratio of 45times/minute.

摇摆试验:吊重200 g,然后折弯 ± 60 度,频率按45次/分钟.

16AWG	-----	5000cycles Min
18AWG	-----	4500cycles Min
20AWG	-----	2400cycles Min
22AWG	-----	2000cycles Min
24AWG	-----	1500cycles Min
26AWG	-----	1000cycles Min

11.3AC plug drawing/输入插头图面: Attached/附图

11.4AC cable drawing/输入线图面: Attached/附图

11.5DC cable drawing/输出线图面: Attached/附图

11.6Outline drawing/外观图面: Attached/附图

11.7Lable drawing/铭牌图面: Attached/附图

11.8Package drawing/包装图面: Attached/附图

SAMPLE PRIMARY TEST REPORT/样品初测报告

MODEL NO./产品型号:
024C-050400-4
TEST BY/测试人: 刘翊豪

Test Items./测试项目	Test Condition/测试条件	Unit/单位	Sample quantity and test result/样品数量和测试结果										Pass/Fail	
			1#	2#	3#	4#	5#	6#	7#	8#	9#	10#		
Unload output voltage/ 空载输出电压 (0.0A) 4.6vdc - 5.4vdc	90Vac	V	5.23	5.22	5.25	5.22	5.26							PASS
	115Vac	V	5.23	5.22	5.25	5.22	5.26							PASS
	230Vac	V	5.23	5.22	5.25	5.22	5.26							PASS
	264Vac	V	5.23	5.22	5.25	5.22	5.26							PASS
Rated load output voltage/ 额定负载输出电压 (4 A) 4.6vdc - 5.4vdc	90Vac	V	4.71	4.70	4.75	4.73	4.75							PASS
	115Vac	V	4.71	4.70	4.75	4.73	4.75							PASS
	230Vac	V	4.71	4.70	4.75	4.73	4.75							PASS
	264Vac	V	4.71	4.70	4.75	4.73	4.75							PASS
Output ripple & noise voltage (Full load)/输出纹波及噪声电压 (满载) < 300mV	90Vac	mV	97	98	144	115	97							PASS
	115Vac	mV	96	92	111	109	98							PASS
	230Vac	mV	92	87	104	104	92							PASS
	264Vac	mV	91	88	106	102	94							PASS
Short-circuit protection test/短路保护测试	90Vac	W	3.1	3.2	2.71	3.3	2.300							PASS
	264Vac	W	1.18	1.11	0.81	1.67	1.140							PASS
Over current protection/过流保护点 (> 4 A)	90Vac	A	4.50	4.50	4.5	4.5	4.50							PASS
	264Vac	A	4.60	4.60	4.6	4.6	4.60							PASS
IC Vcc voltage test/Vcc电压测试 (规格 ≤ 27V)	90Vac	V	15.21	14.50	14.6	15.24	14.68							PASS
	264Vac	V	14.55	14.18	15	15.04	15.01							PASS
Hi-pot test/介电强度	4242Vdc/3.5mA/1Minute		OK	OK	OK	OK	OK							PASS
Appearance/外观	无刮伤,字迹清晰 无误		OK	OK	OK	OK	OK							PASS
Mosfet(IC)/Vds耐压测试	264Vac	V	550	Mosfet规格			600	Derating ≤ 95% Max. Volt.		91.67%			PASS	
输出肖特基D/Vrr耐压测试	264Vac	V	37.2	Diode规格			55	Derating ≤ 95% Max. Volt.		67.64%			PASS	
变压器反馈绕组上所连接电阻 (R) 功率损耗(PD)	90Vac	P	-	R(功率)规格			-	Derating ≤ 65% Max Power		-			PASS	
	264Vac	P	-	R(功率)规格			-	Derating ≤ 65% Max Power		-			PASS	

E0-3-011 G/1

Energy Efficiency Level VI/Erp 2 test/能效测试

MODEL NO./产品型号:

024C-050400-4

TEST BY/测试人: 刘翊豪

Environment : ● Ambient ○ High ○ Low : 25°C

Test Condition: Vac=115V/230V ,Load :0~100% step Load :25%

1 Vin: 115Vac/60Hz							
Load (%)	Vout(V)	Iout(A)	PF	Pin(w)	Po(w)	Efficiency	Result
0	5.23	0.000	---	0.02	0	0.00%	PASS
10	5.18	0.400	---	2.38	2.072	87.06%	74.24%
25	5.10	1.000	---	5.85	5.1	87.18%	---
50	4.97	2.000	---	11.68	9.94	85.10%	---
75	4.84	3.000	---	17.53	14.52	82.83%	---
100	4.71	4.000	---	23.41	18.84	80.48%	---
Po_typical (w)				20	Average 83.90%		PASS
					Spec. 83.68%		VI

1 Vin: 230Vac/50Hz							
Load (%)	Vout(V)	Iout(A)	PF	Pin(w)	Po(w)	Efficiency	Result
0	5.23	0.000	---	0.03	0	0.00%	PASS
10	5.18	0.400	---	2.45	2.072	84.57%	74.24%
25	5.10	1.000	---	5.87	5.1	86.88%	---
50	4.97	2.000	---	11.66	9.94	85.25%	---
75	4.84	3.000	---	17.46	14.52	83.16%	---
100	4.71	4.000	---	23.3	18.84	80.86%	---
Po_typical (w)				20	Average 84.04%		PASS
					Spec. 83.68%		VI

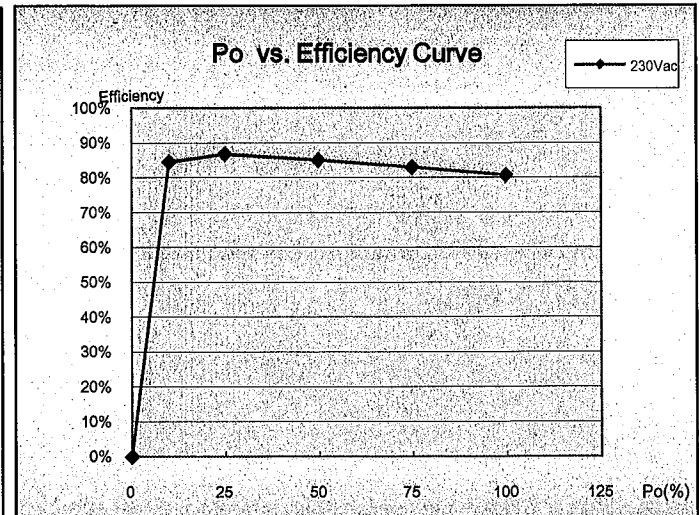
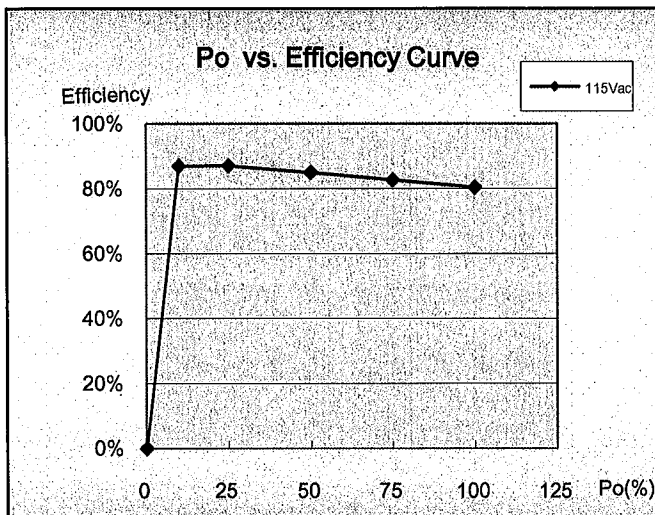

版本	变更内容	变更人	变更时间

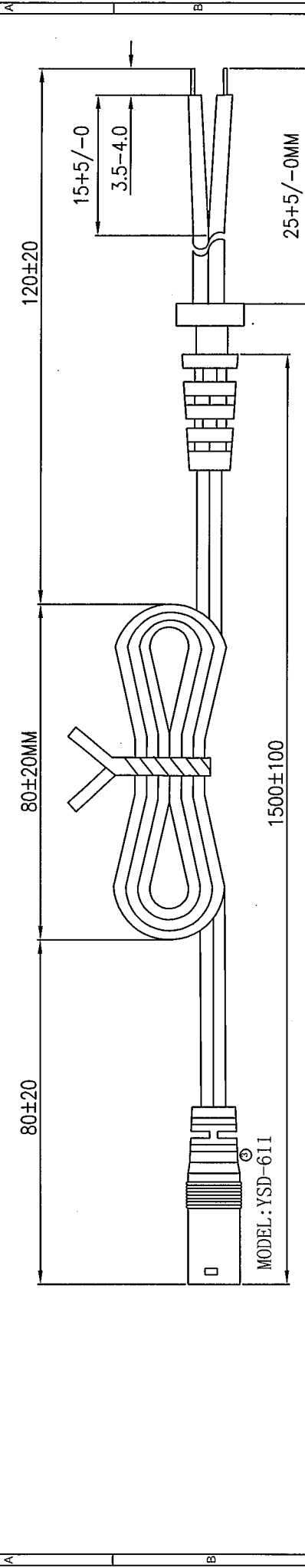

线材规格: 黑色 18# SPT-1 DC 母头配一可换插头

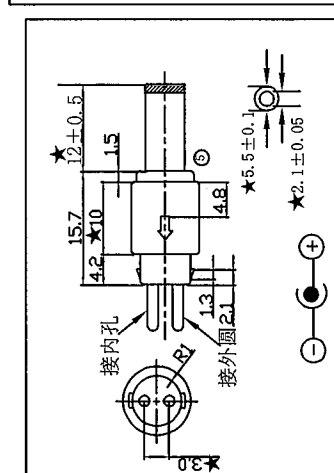

箭头指示正极
★为重点尺寸

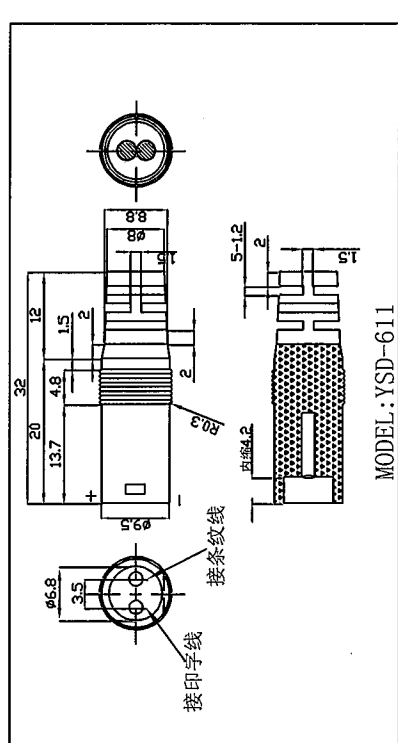

DC 头规格:
编号: YSD611
包胶材质: 50+/-5P PVC 黑色

DC 头规格: 平头黑胶 2.1X5.5X12 直头
DC 直头配母头可拆卸转换

SR 规格:
编号: YX462(828)
材质: 70+/-5P PVC 黑色

技术要求:

1. 线材摇摆测试, 拉力测试: 吊重 200g, 吊距 30cm, 旋转 40-45 次/分钟, 摇摆度 120°, 摇摆 4500 次以上。判定结果为线身无断裂、无破皮、铜线无断开, DC 头焊接处无接触不良。
2. 热变形温度大于 60 度。
3. 产品必须符合 ROHS+PAHS+16P 要求。
4. 注意公差要求。

