

1.INPUT/输入特性

1.1 Input voltage rating/额定输入电压范围:	100-240V AC	33774C28
1.2 Input voltage range/输入电压范围:	90-264V AC	
1.3 Input frequency rating/额定输入频率:	60/50 Hz	
1.4 Input frequency range/输入频率范围:	63/47 Hz	
1.5 AC input current/最大输入电流:	0.75 A Max .@100V AC	
1.6 AC input power saving/输入空载功率:	0.075 W Max .@230V AC at no load	
1.7 Inrush Current/最大浪涌电流:	30 A Max .@100VAC (Cold start/冷启动)	
	60 A Max .@230VAC (Cold start/冷启动)	
1.8 Leakage current/最大漏电流:	0.25mA Max	

2. Output characteristics/输出特性

2.1 Output voltage/输出电压:	18 V
2.2 Max. load current/最大负载电流:	1.33 A
2.3 Min. load current/最小负载电流:	0 A
2.4 Output no-load voltage/输出空载电压:	18 V± 5%
2.5 Output full load voltage/输出满载电压:	18 V± 5%
2.6 Output ripple & noise/输出纹波与噪声:	200 mV max.

Note: 1. output voltages shall be measured at output connector.

2. Ripple measurements shall be made with an oscilloscope of at least 20 MHz bandwidth. Output shall be bypassed at the connector with a 0.1uF ceramic disk capacitor and a 10uF electrolytic capacitor to simulate system loading at temperature 25°C

1. 输出电压要求测试连接输出端。

2. 纹波测试要求在环境温度25度情况下示波器频宽在20MHz以下，量测输出连接端并联一个10uF电解电容与0.1uF的独石电容。

3. General characteristics/一般特性

3.1 Total output power/额定总输出功率:	23.94 Watts
3.2 Average Efficiency / 平均效率:	While input 115Vac and 230Vac, the average efficiency is more than 86.79% .The test point is at 25%,50%,75% and 100% load after 30 min warm up at max load.comply must with requirements level VI 在输入115Vac和230Vac条件下，平均效率不小于 86.79% 测试点分别是最大载的25%, 50%, 75% 和 100%。测试要求电源满载预热30分钟测试。必需符合能效六等级要求。
3.3 Short circuit protection/短路保护:	A Short circuit placed on DC output shall cause no damage or auto-recovery the power supply. 输出短路时电源不会损坏或自动还原供电。
3.4 Over Voltage Protection/过压保护:	When overvoltage occurs on DC output shall cause no damage or auto-recovery the power supply. 输出过压发生时电源不会损坏或自动还原供电。

4. Environment/环境:

4.1 Operating temperature/:操作温度	<u>0~40°C</u>
4.2 Storage temperature/:存储温度	<u>-25°C to 70°C</u>
4.3 Operating humidity/:环境湿度	<u>8% to 90%</u>
4.4 Storage humidity/:存储湿度	<u>5% to 95%</u>

5. Application safety standard : meet/应用安全标准

<input type="checkbox"/> UL 60950	<input type="checkbox"/> EN 60950	<input type="checkbox"/> AS/NZS 60950	<input type="checkbox"/> J60950	<input type="checkbox"/> K60950
<input type="checkbox"/> UL 60065	<input type="checkbox"/> EN 60065	<input checked="" type="checkbox"/> AS/NZS 60065	<input type="checkbox"/> J60065	
<input type="checkbox"/> UL 1310	<input type="checkbox"/> EN 60335	<input type="checkbox"/> GB4943	<input type="checkbox"/> J61558	
	<input type="checkbox"/> EN 61558	<input type="checkbox"/> GB8898		

6. EMC standard /电磁干扰标准:

6.1 EMI standard / EMI 标准:

<input type="checkbox"/> FCC Part 15 Class B	<input type="checkbox"/> GB 9254-2008	<input type="checkbox"/> J55022
<input checked="" type="checkbox"/> EN 55032: 2015	<input type="checkbox"/> GB 17625.1-2012	<input type="checkbox"/> J55013

6.2 EMS standard / EMS 标准:

<input checked="" type="checkbox"/> EN 61000-4-2/ESD静电耐受测试	<input checked="" type="checkbox"/> EN 61000-4-5/Surge点击波耐受测试
<input checked="" type="checkbox"/> EN 61000-4-3/RS辐射场强耐受测试	<input checked="" type="checkbox"/> EN 61000-4-6/CS传导场强耐受测试
<input checked="" type="checkbox"/> EN 61000-4-4/EFT/Burst瞬间脉冲耐受测试	

7. HI-POT test/高压测试

(1)Primary to secondary/:初级对次级	<u>4525VDC for 3sec. 5mA(production testing)</u>
	<u>4242VDC for 1min. 5mA(Sample testing)</u>
(2)Primary to case/:初级对外壳 (only for metal case)只适用于金属外壳	<u>4525VDC for 3sec 5mA(Production test)</u>

8. Insulation resistance /绝缘电阻

Input to output/输入对输出:	<u>>10Mohm.@500VDC</u>
------------------------	---------------------------

9. Reliability:/ 可靠性

9.1 MTBF/平均故障间隔时间:	<u>50K hours min. @full load at 25°C ambient temperature.</u>
--------------------	---

9.2 Burn-in/烘烤:	<u>2-4hours,25~45°C ,Input 220VAC,Output 80% load .</u>
-----------------	---

9.3 Altitude: Will operate properly at altitude between 0 to 6000ft

正常运转在0到6000英尺之间的高度.

10. Mechanical/ 机械结构

10.1 Dimensions/尺寸:Please see the mechanical dimension drawing./请参见机械尺寸图

10.2 Weight/重量: _____ g

11. Mechanical specification/机械参数:

11.1 Drop test/落地测试: The height of 1 M,frequency 1 drop per face.

dropping surface on concrete floor judgment standard:No function fail & no cabinet joint broken.

11.2 Bending test: With load 200g, then bend ± 60 degree at ratio of 45times/minute.

摇摆试验:吊重200 g,然后折弯 ± 60 度,频率按45次/分钟.

16AWG	-----	5000cycles Min
18AWG	-----	4500cycles Min
20AWG	-----	2400cycles Min
22AWG	-----	2000cycles Min
24AWG	-----	1500cycles Min
26AWG	-----	1000cycles Min

11.3AC plug drawing/输入插头图面: Attached/附图

11.4AC cable drawing/输入线图面: Attached/附图

11.5DC cable drawing/输出线图面: Attached/附图

11.6Outline drawing/外观图面: Attached/附图

11.7Lable drawing/铭牌图面: Attached/附图

11.8Package drawing/包装图面: Attached/附图

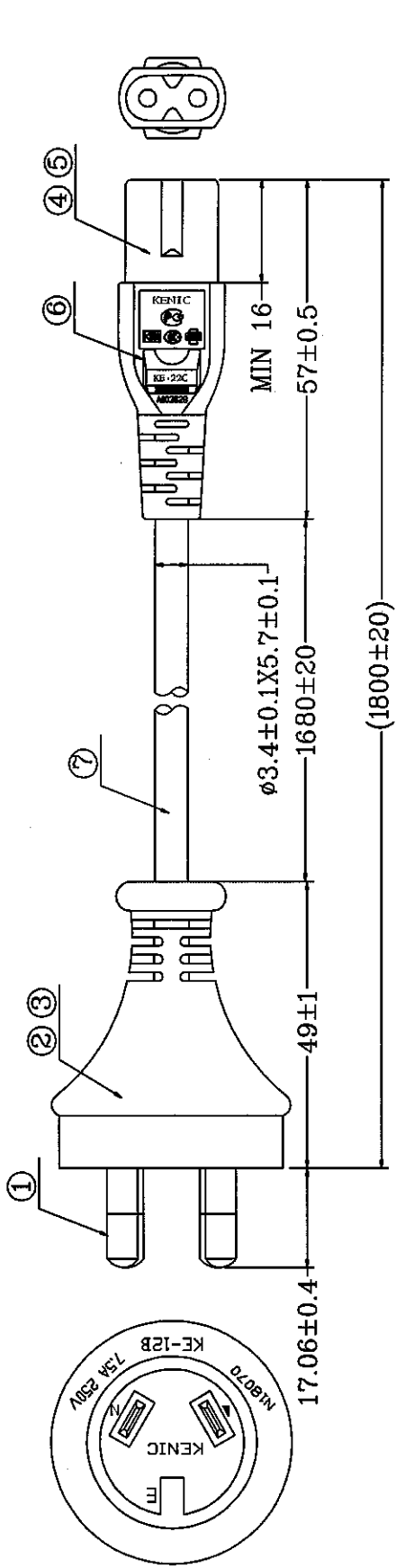

注：1. 插头需套插脚护套。

2. 电线印字内容

KENIC * < VDE > KEMA-KEUR < ÜVE > CE BEC 1139

+ + + + + IEMMEQU ⊙ ⊙ ⊙ NF-USE

1327 KELF-75 N15075 H03VVH2-F 2X0.75mm²

300/300V RS

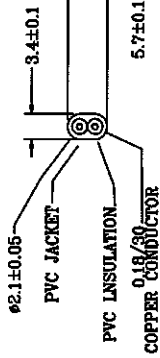
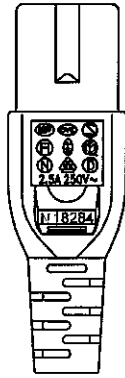
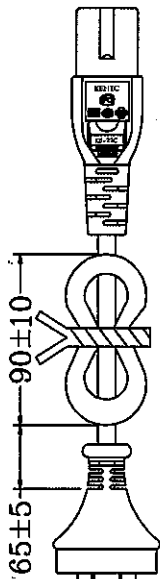

AC线剖面图

详细证书，尺寸请见文档GPE-SAA.PDF

10	装箱数量					
9	电线单重					
8	扎带		扎带	1 PC	黑色	
7	电线	BK01W81DX	H03VVH2-F 2X0.75mm ² (印字)	1165±15	黑色	
6	外模	BK01P90EX	KE-22C外模 注塑外模 PVC	9.2 g	黑色	
5	内套	MA-018C-01	内套	1 PC	黑色	
4	端子	MA-022C-01	梅花磷铜端子	2 PCS	—	
3	外模	BK01P90EX	KE-12B外模 注塑外模 PVC	34.5 g	黑色	
2	内套	MA-013B-02	内套	1 PC	黑色	
1	五金插片	MA-013B-01	SAA绝缘铜片	2 PCS	黑色	
序号	名称	物料料号	描述	数量	颜色	

版本	变更内容	变更人	变更时间
B	SR内长变更25±5MM	向增娟	2016.07.13

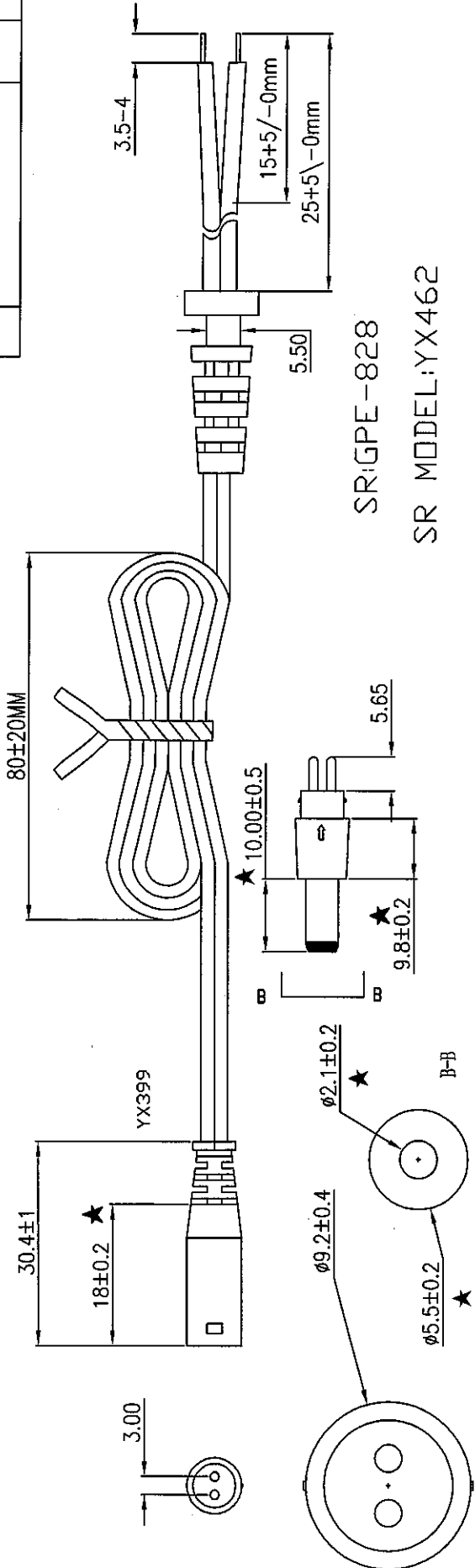

SRIGPE-828
SR MODEL:YX462

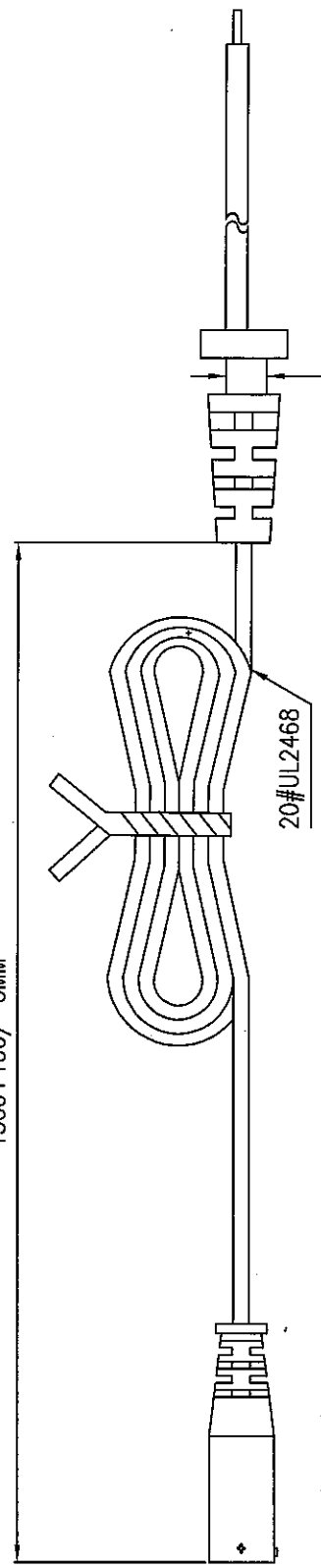

★ 为重点尺寸

技术要求:

1. 线材摇摆测试, 拉力测试: 吊重200g, 吊距30cm, 旋转40-45次/分钟, 摇摆度120°, 摇摆2400次以上。判定结果为线身无断裂、无破皮、铜线无断开, DC头焊接处无接触不良。
2. 热变形温度大于60度。
3. 产品必须符合ROHS+PAHS+16P要求。
4. 注意公差要求。

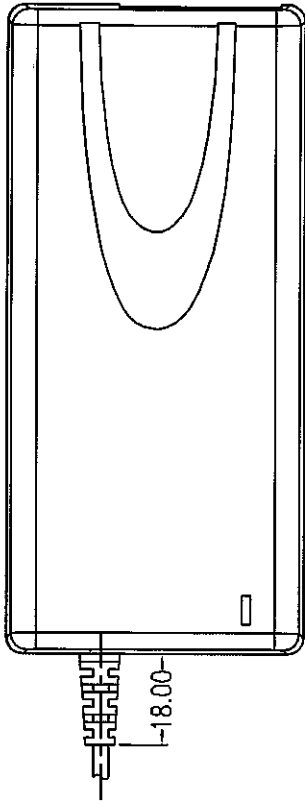

31.5±1

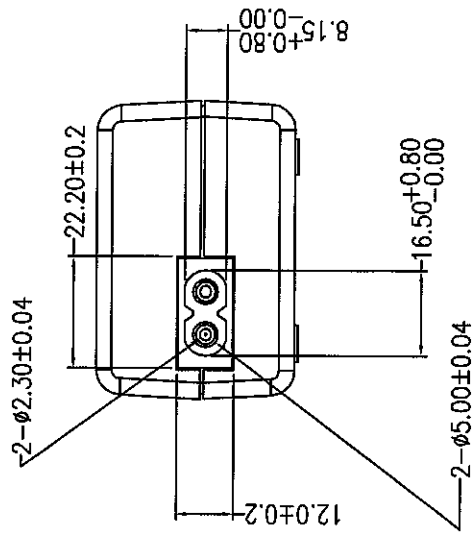
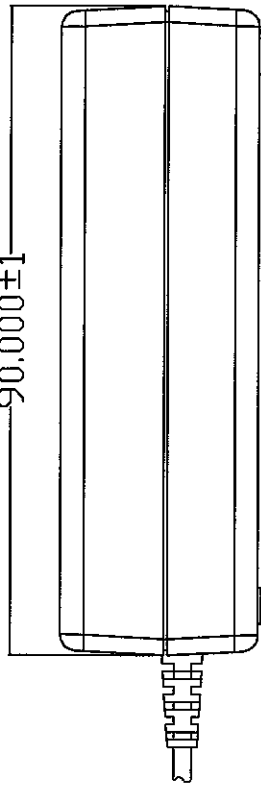

DATE CODEYYMM
YY:YEAR
MM:WEEK

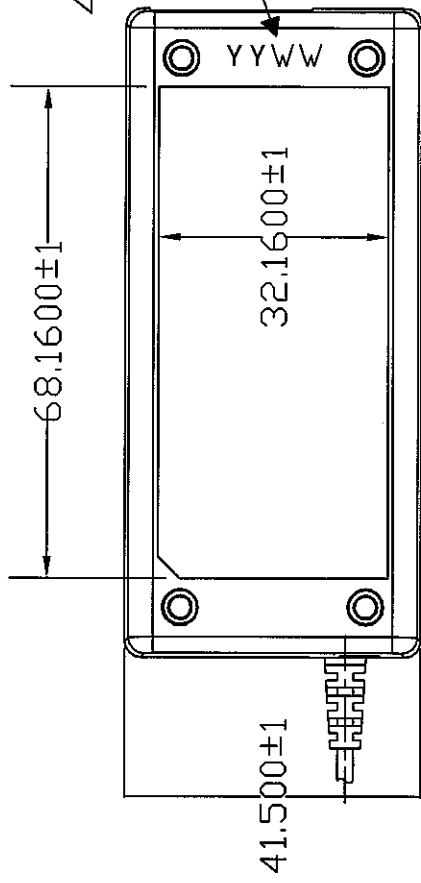

选择	颜色	料号
●	黑色	10-0241-0008
	白色 (AB30)	
	苹果白 AB301 (185669)	10-0241-0011
	灰色 (426C)	