

1.INPUT/输入特性

| | | |
|------------------------------------|------------------------------------|----------------|
| 1.1 Input voltage rating/额定输入电压范围: | 100-240V AC | code : 3377427 |
| 1.2 Input voltage range/输入电压范围: | 90-264V AC | |
| 1.3 Input frequency rating/额定输入频率: | 60/50 Hz | |
| 1.4 Input frequency range/输入频率范围: | 63/47 Hz | |
| 1.5 AC input current/最大输入电流: | 0.75 A Max .@100V AC | |
| 1.6 AC input power saving/输入空载功率: | 0.3 W Max .@230V AC at no load | |
| 1.7 Inrush Current/最大浪涌电流: | 30 A Max .@100VAC (Cold start/冷启动) | |
| | 60 A Max .@230VAC (Cold start/冷启动) | |
| 1.8 Leakage current/最大漏电流: | 0.25mA Max | |

2. Output characteristics/输出特性

| | |
|--------------------------------------|-------------|
| 2.1 Output voltage/输出电压: | 15 V |
| 2.2 Max. load current/最大负载电流: | 1.6 A |
| 2.3 Min. load current/最小负载电流: | 0 A |
| 2.4 Output no-load voltage/输出空载电压: | 15 V± 5% |
| 2.5 Output full load voltage/输出满载电压: | 15 V± 5% |
| 2.6 Output ripple & noise/输出纹波与噪声: | 250 mV max. |

Note: 1. output voltages shall be measured at output connector.

2. Ripple measurements shall be made with an oscilloscope of at least 20 MHz bandwidth. Output shall be bypassed at the connector with a 0.1uF ceramic disk capacitor and a 10uF electrolytic capacitor to simulate system loading at temperature 25° :

1.输出电压要求测试连接输出端。

2.纹波测试要求在环境温度25度情况下示波器频宽在20MHz以下,量测输出连接端并联一个10uF电解电容与0.1uF的独石电容。

3. General characteristics/一般特性

| | |
|------------------------------------|---|
| 3.1 Total output power/额定总输出功率: | 24 Watts |
| 3.2 Average Efficiency / 平均效率: | While input 115Vac and 230Vac, the average efficiency is more than 82.22% .The test point is at 25%,50%,75% and 100% load after 30 min warm up at max load. must comply with CEC requirements . level V 在输入115Vac和230Vac条件下,平均效率不小于 82.22% 测试点分别是最大载的25%, 50%, 75% 和 100%. 测试要求电源满载预热30分钟测试. 必需符合CEC要求。 |
| 3.3 Short circuit protection/短路保护: | A Short circuit placed on DC output shall cause no damage or auto-recovery the power supply. 输出短路时电源不会损坏或自动还原供电。 |
| 3.4 Over Voltage Protection/过压保护: | When overvoltage occurs on DC output shall cause no damage or auto-recovery the power supply. 输出过压发生时电源不会损坏或自动还原供电。 |

4. Environment/环境:

| | |
|---------------------------------|---------------|
| 4.1 Operating temperature/:操作温度 | 0~40°C |
| 4.2 Storage temperature/:存储温度 | -25°C to 70°C |
| 4.3 Operating humidity/:环境湿度 | 8% to 90% |
| 4.4 Storage humidity/:存储湿度 | 5% to 95% |

5. Application safety standard : meet/应用安全标准

| | | | | |
|-----------------------------------|-----------------------------------|--|---------------------------------|---------------------------------|
| <input type="checkbox"/> UL 60950 | <input type="checkbox"/> EN 60950 | <input checked="" type="checkbox"/> AS/NZS 60950 | <input type="checkbox"/> J60950 | <input type="checkbox"/> K60950 |
| <input type="checkbox"/> UL 60065 | <input type="checkbox"/> EN 60065 | <input type="checkbox"/> AS/NZS 60065 | <input type="checkbox"/> J60065 | <input type="checkbox"/> Brazil |
| <input type="checkbox"/> UL 1310 | <input type="checkbox"/> EN 60335 | <input type="checkbox"/> GB4943 | <input type="checkbox"/> J61558 | |
| | <input type="checkbox"/> EN 61558 | <input type="checkbox"/> GB8898 | | |

6. EMC standard /电磁干扰标准:

6.1 EMI standard / EMI 标准:

| | | |
|--|--|---------------------------------|
| <input type="checkbox"/> FCC Part 15 Class B | <input type="checkbox"/> GB 9254-2008 | <input type="checkbox"/> J55022 |
| <input checked="" type="checkbox"/> EN 55022: 2010+AC:2011 | <input type="checkbox"/> GB 17625.1-2012 | <input type="checkbox"/> J55013 |
| <input type="checkbox"/> EN 55013: 2013 | | |

6.2 EMS standard / EMS 标准:

| | |
|--|---|
| <input checked="" type="checkbox"/> EN 61000-4-2/ESD静电耐受测试 | <input checked="" type="checkbox"/> EN 61000-4-5/Surge点击波耐受测试 |
| <input checked="" type="checkbox"/> EN 61000-4-3/RS辐射场强耐受测试 | <input checked="" type="checkbox"/> EN 61000-4-6/CS传导场强耐受测试 |
| <input checked="" type="checkbox"/> EN 61000-4-4/EFT/Burst瞬间脉冲耐受测试 | |

7. HI-POT test/高压测试

| | |
|---|---|
| (1)Primary to secondary/:初级对次级 | 4525VDC for 3sec. 5mA(production testing) |
| | 4242VDC for 1min. 5mA(Sample testing) |
| (2)Primary to case/:初级对外壳 (only for metal case)只适用于金属外壳 | 4525VDC for 3sec 5mA(Production test) |

8. Insulation resistance /绝缘电阻

| | |
|------------------------|-----------------|
| Input to output/输入对输出: | >10Mohm.@500VDC |
|------------------------|-----------------|

9. Reliability:/ 可靠性

| | |
|--|--|
| 9.1 MTBF/平均故障间隔时间: | 50K hours min. @full load at 25°C ambient temperature. |
| 9.2 Burn-in/烘烤: | 2-4hours,25~45°C ,Input 220VAC,Output 80% load . |
| 9.3 Altitude: Will operate properly at altitude between 0 to 6000ft 正常运转在0到6000英尺之间的高度. | |

10. Mechanical/ 机械结构

10.1 Dimensions/尺寸:Please see the mechanical dimension drawing./请参见机械尺寸图

10.2 Weight/重量: _____ g

11. Mechanical specification/机械参数:

11.1 Drop test/落地测试: The height of 1 M,frepuency 1 drop per face.

dropping surface on concrete floor judgment standard:No function fail & no cabinet joint broken.

11.2 Bending test: With load 200g, then bend ± 60 degree at ratio of 45times/minute.

摇摆试验:吊重200 g,然后折弯 ± 60 度,频率按45次/分钟.

| | |
|-------------|----------------|
| 16AWG ----- | 5000cycles Min |
| 18AWG ----- | 4500cycles Min |
| 20AWG ----- | 2400cycles Min |
| 22AWG ----- | 2000cycles Min |
| 24AWG ----- | 1500cycles Min |
| 26AWG ----- | 1000cycles Min |

11.3AC plug drawing/输入插头图面: Attached/附图

11.4AC cable drawing/输入线图面: Attached/附图

11.5DC cable drawing/输出线图面: Attached/附图

11.6Outline drawing/外观图面: Attached/附图

11.7Lable drawing/铭牌图面: Attached/附图

11.8Package drawing/包装图面: Attached/附图

SAMPLE PRIMARY TEST REPORT/样品初测报告

MODEL NO./产品型号: 248-150160-4

TEST BY/测试人: 刘翊豪

| Test Items./测试项目 | Test Condition/测试条件 | Unit/单位 | Sample quantity and test result/样品数量和测试结果 | | | | | | | | | | Pass/Fail | |
|--|---------------------------|---------|---|----------|-------|----|----|------------------------------|--------|----|----|-----|-----------|------|
| | | | 1# | 2# | 3# | 4# | 5# | 6# | 7# | 8# | 9# | 10# | | |
| Unload output voltage/ 空载输出电压 (0.0A) 14.25vdc - 15.75vdc | 90Vac | V | 15.25 | 15.33 | 15.27 | | | | | | | | | PASS |
| | 115Vac | V | 15.25 | 15.33 | 15.27 | | | | | | | | | PASS |
| | 230Vac | V | 15.25 | 15.33 | 15.27 | | | | | | | | | PASS |
| | 264Vac | V | 15.25 | 15.33 | 15.26 | | | | | | | | | PASS |
| Rated load output voltage/ 额定负载输出电压 (1.6 A) 14.25vdc - 15.75vdc | 90Vac | V | 14.99 | 15.10 | 15.04 | | | | | | | | | PASS |
| | 115Vac | V | 14.99 | 15.10 | 15.04 | | | | | | | | | PASS |
| | 230Vac | V | 14.99 | 15.10 | 15.04 | | | | | | | | | PASS |
| | 264Vac | V | 14.99 | 15.10 | 15.04 | | | | | | | | | PASS |
| Output ripple & noise voltage (Full load)/输出 纹波及噪声 电压 (满载) ≤ 250mV | 90Vac | mV | 112 | 122 | 121 | | | | | | | | | PASS |
| | 115Vac | mV | 83 | 97 | 99 | | | | | | | | | PASS |
| | 230Vac | mV | 90 | 92 | 82 | | | | | | | | | PASS |
| | 264Vac | mV | 88 | 95 | 79 | | | | | | | | | PASS |
| Short-circuit protection test/短路保护测试 | 90Vac | W | 0.015 | 0.009 | 0.004 | | | | | | | | | PASS |
| | 264Vac | W | 0.11 | 0.14 | 0.14 | | | | | | | | | PASS |
| Over current protection/ 过流保护点 (≥ 1.92 A) | 90Vac | A | 2.40 | 2.30 | 2.40 | | | | | | | | | PASS |
| | 264Vac | A | 3.10 | 3.10 | 3.10 | | | | | | | | | PASS |
| IC Vcc voltage test/ Vcc电压测试 (规格 ≤ 27V) | 90Vac | V | 23.19 | 23.24 | 23.01 | | | | | | | | | PASS |
| | 264Vac | V | 23.20 | 23.34 | 23.64 | | | | | | | | | PASS |
| Hi-pot test/介电强度 | 4242Vdc/3.5mA/ 1Minute | | OK | OK | OK | | | | | | | | | PASS |
| Appearance/外观 | 无刮伤,字迹清晰 无误 | | OK | OK | OK | | | | | | | | | PASS |
| Mosfet (IC)/Vds耐压测试 | 264Vac | V | 546 | Mosfet规格 | 600 | | | Derating ≤ 95% Max. Volt. | 91.00% | | | | | PASS |
| 输出肖特基D/Vrr耐压测试 | 264Vac | V | 81 | Diode规格 | 100 | | | Derating ≤ 90% Max. Volt. | 81.00% | | | | | PASS |
| 变压器反馈绕组上所连接电 阻 (R)功率损耗(PD) | 90Vac | P | - | R(功率)规格 | - | | | Derating ≤ 65% Max Power | - | | | | | PASS |
| | 264Vac | P | - | R(功率)规格 | - | | | Derating ≤ 65% Max Power | - | | | | | PASS |

E0-3-011 G/1

CEC/ERP 2 test/能效测试

MODEL NO./产品型号:

248-150160-4

TEST BY/测试人: 刘翊豪

Environment : Ambient High Low : 25°C

Test Condition: Vac=115V/230V ,Load :0~100% step Load :25%

| 1 Vin: 115Vac/60Hz | | | | | | | | 1 Vin: 230Vac/50Hz | | | | | | | | |
|--------------------|---------|---------|-----|--------|-----------------------------------|------------|-------------|--------------------|----------------|---------|-----|--------|--------|-----------------------------------|-------------|--|
| Load (%) | Vout(V) | Iout(A) | PF | Pin(w) | Po(w) | Efficiency | Result | Load (%) | Vout(V) | Iout(A) | PF | Pin(w) | Po(w) | Efficiency | Result | |
| 0 | 15.25 | 0.00 | --- | 0.03 | 0 | 0.00% | PASS | 0 | 15.25 | 0.00 | --- | 0.16 | 0 | 0.00% | PASS | |
| 25 | 15.19 | 0.40 | --- | 7.24 | 6.076 | 83.92% | --- | 25 | 15.19 | 0.40 | --- | 7.33 | 6.076 | 82.89% | --- | |
| 50 | 15.13 | 0.80 | --- | 14.28 | 12.104 | 84.76% | --- | 50 | 15.13 | 0.80 | --- | 14.32 | 12.104 | 84.53% | --- | |
| 75 | 15.07 | 1.20 | --- | 21.44 | 18.084 | 84.35% | --- | 75 | 15.07 | 1.20 | --- | 21.34 | 18.084 | 84.74% | --- | |
| 100 | 15.01 | 1.60 | --- | 28.74 | 24.016 | 83.56% | --- | 100 | 15.01 | 1.60 | --- | 28.33 | 24.016 | 84.77% | --- | |
| Po_typical (w) | | | | 24 | Average 84.15% PASS | | | | Po_typical (w) | | | | 24 | Average 84.23% PASS | | |
| | | | | | Spec. 82.22% V | | | | | | | | | Spec. 82.22% V | | |

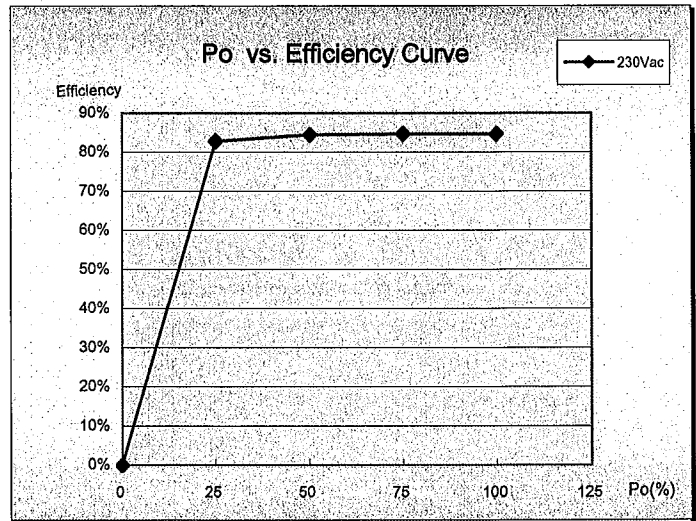
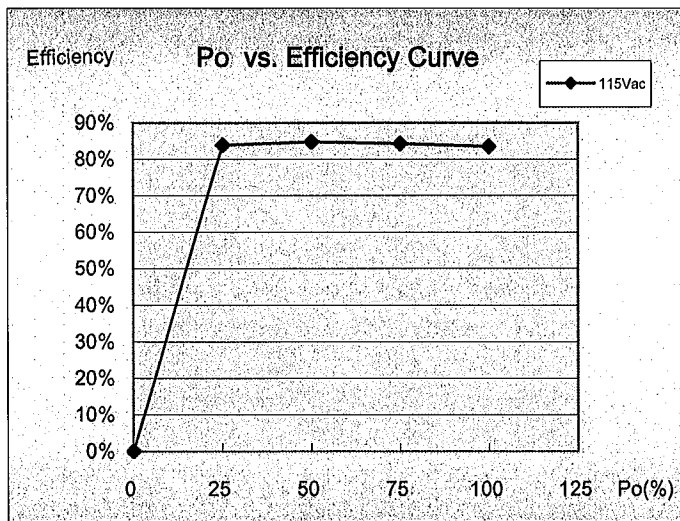

| | | | |
|----|---------|-----|------------|
| 版本 | 变更内容 | 变更人 | 变更时间 |
| C | DC头模具变更 | 向增娟 | 2012.11.14 |

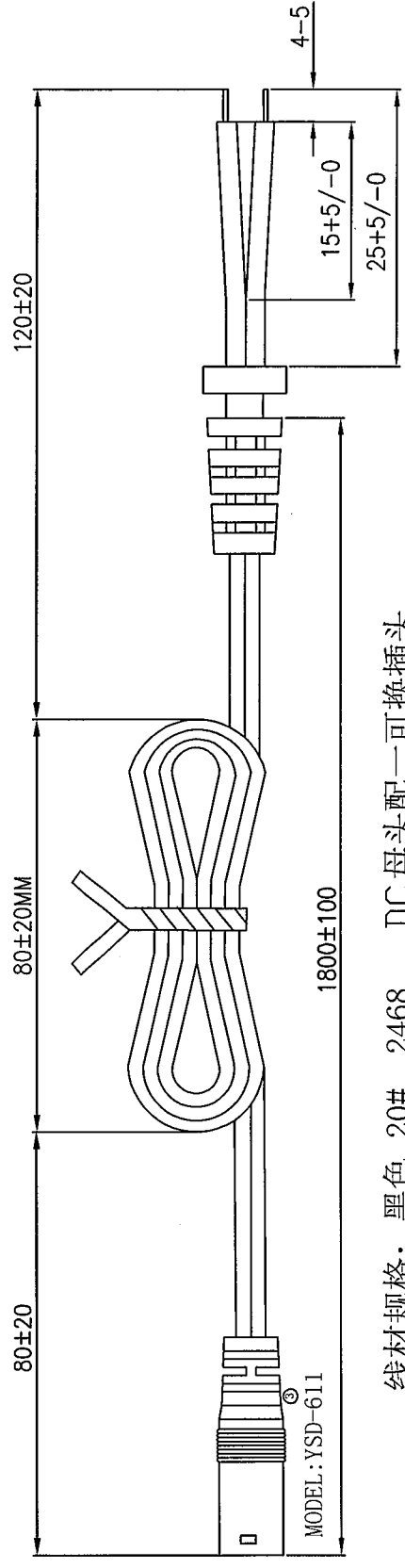

线材规格：黑色 20# 2468 DC 母头配一可换插头

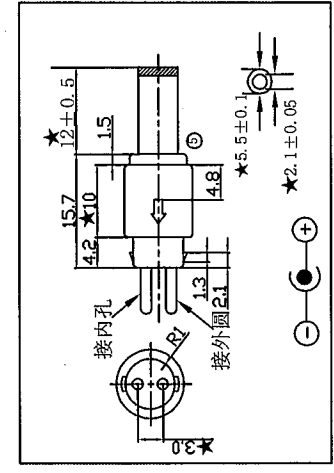

箭头指示正极
★为重点尺寸

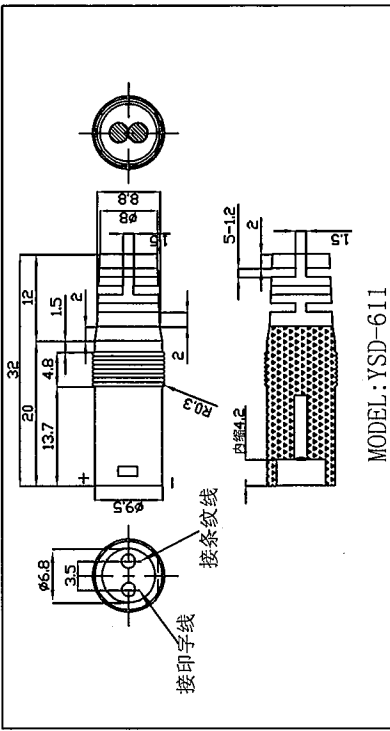

DC头规格：
编号：YSD611
包胶材质：50+/-5P PVC 黑色
DC头规格：平头黑胶2.1X5.5X12直头
DC直头配母头可拆卸转换

★为重点尺寸

技术要求：

1. 线材摇摆测试，拉力测试依照金盈线材测试标准。
2. 热变形温度大于60度。
3. 产品必须符合ROHS+PAHS+16P要求。

SR规格：
编号：YX462(828)
材质：70+/-5P PVC 黑色

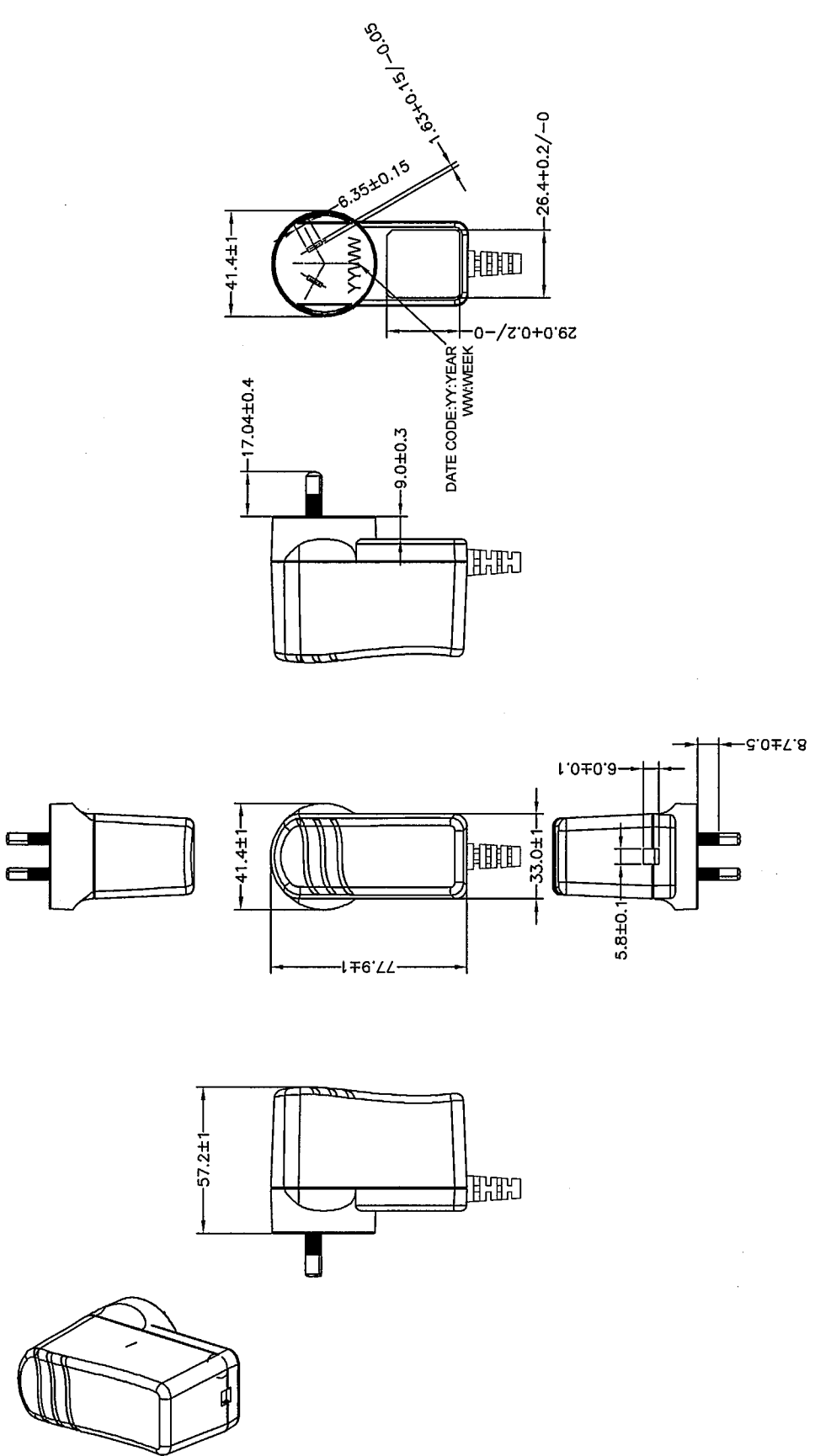

1. This drawing is the property of the company and is not to be distributed, copied, or used in any way without the written permission of the company.

