

# Ensemble

USER MANUAL



 **Avantree**<sup>®</sup>

Model No.: BTH-5150



EN	User Manual	2
DE	Bedienungsanleitung	17
FR	Guide de démarrage rapide	32
IT	Guida di avvio rapido	47
ES	Guía de inicio rápido	62
JP	取扱説明書	77

## Video Guide

Prefer to watch a video tutorial? Scan the QR code below or visit [avantree.com/ensemble/video](https://avantree.com/ensemble/video) for a step-by-step guide.

EN



## Book an Appointment



You can also book a 1-on-1 setup appointment with one of our support agents at [avantree.com/book-a-call](https://avantree.com/book-a-call)

# Table of Contents

<b>Box Contents</b> .....	4
<b>Product Introduction</b> .....	5
Product Overview .....	5
Button Functions .....	6
LED Indicators .....	6
<b>Setup</b> .....	7
Connecting the Transmitter to Your TV .....	7
Option 1 - Optical port (recommended) .....	7
Option 2 - AUX 3.5mm port .....	8
Option 3 - RCA port .....	8
Connecting the Headphones to Transmitter .....	9
Setting Up Your TV (for optical connections only) .....	10
<b>Advanced Features</b> .....	11
Adding a Second Pair of Headphones .....	11
Using the Headphones with Your Phone/Tablet .....	12
<b>Charging the Headphones</b> .....	13
<b>Specifications</b> .....	14
<b>FAQ</b> .....	15
<b>Contact Us</b> .....	16

# Box Contents

EN



Headphones

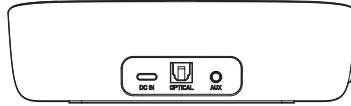

Transmitter / Charging Dock

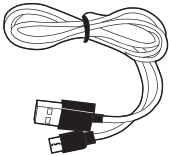

Power Cable for Transmitter

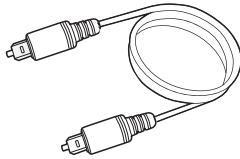

Optical Audio Cable

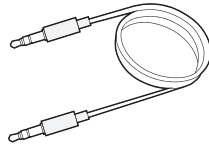

Aux 3.5mm Audio Cable

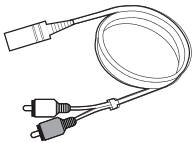

Aux 3.5mm to RCA Adapter

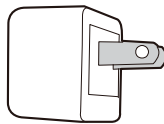

USB Adapter

To view and purchase Ensemble accessories, please visit [avantree.com/ensemble/accessories](http://avantree.com/ensemble/accessories)

# Product Introduction



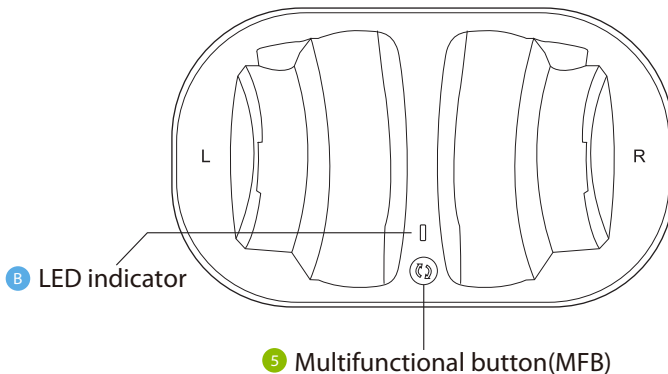
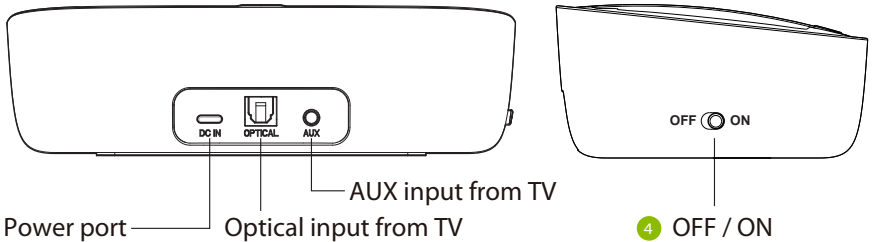
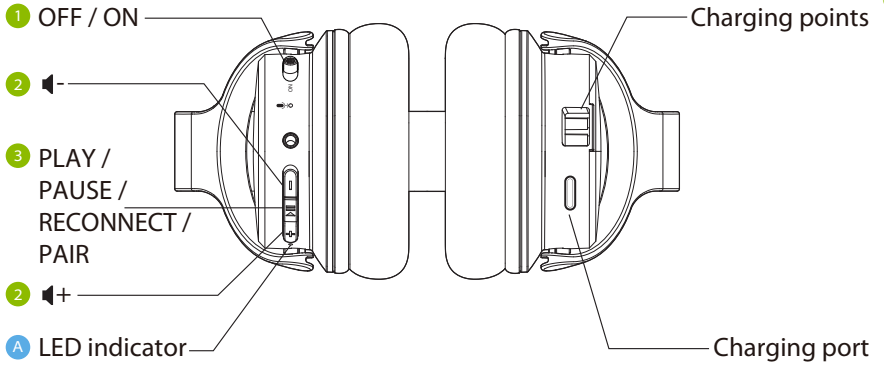

## Product Overview

EN



## Button Functions

EN

No.	Button	Function
1	ON  OFF	Switch to turn the headphones on / off
2	+ / -	Press or hold to adjust volume
3		If headphones fail to auto-connect to transmitter, press once to activate reconnection
		Press & hold for 5 seconds to place the headphones into pairing mode
		Press once to play / pause audio (when used separately with phone / tablet)
4	OFF  ON	Switch to turn the transmitter on / off
5		Press & hold for 5 seconds to place the transmitter into pairing mode

## LED Indicators

No.	Indicator	Status
A	Flashing blue	Power on
	Solid blue	Connected
	Flashing red & blue	Pairing mode
	Flashing red	Low battery
	Solid red	Charging
	Off	Charging complete
B	Flashing blue	Power on
	Solid blue	Connected
	Flashing red & blue	Pairing mode
	Solid red	Charging
	Solid green	Charging complete



## Setup

### Connecting the Transmitter to Your TV

The transmitter must be connected to a power source in order to function. Connect it to a nearby wall outlet via the provided USB adapter and power cable.

Once the transmitter is connected to its power source, you can connect it to your TV's audio ports. You can choose one of 3 different ways to do this:

#### OPTION 1 - Optical port (recommended)

Plug the provided optical audio cable into the TV's DIGITAL AUDIO OUT (OPTICAL) port, then plug the other end into the transmitter's optical port.

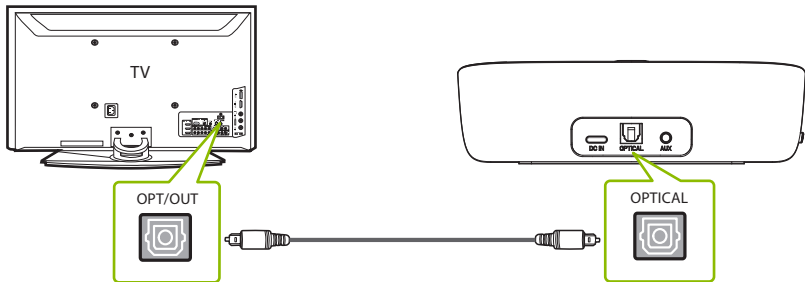

*NOTE: Most TVs support audio output through only one digital output port at a time, so if your TV's HDMI ARC port is in use, the optical port may be disabled. You can either unplug the HDMI ARC or try connecting the transmitter via RCA / AUX.*

**OPTION 2** - AUX 3.5mm port

Plug the provided AUX 3.5mm audio cable into the TV's AUX 3.5mm output port, then plug the other end into the transmitter's AUX 3.5mm port.

EN

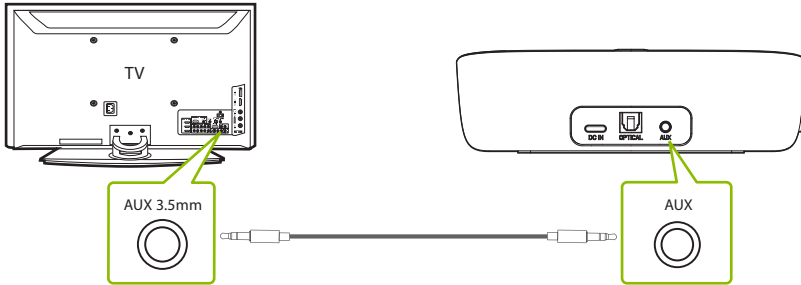
**OPTION 3** - RCA port

Connect the provided RCA adapter to the AUX 3.5mm audio cable. Plug the red & white RCA connectors into the TV's "AUDIO OUT" ports, then plug the other end into the transmitter's AUX 3.5mm port.

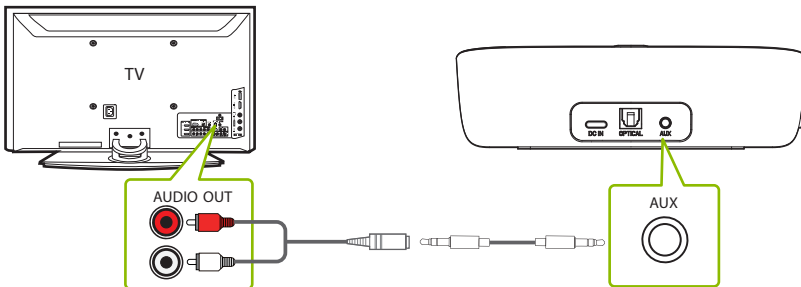

## Connecting the Headphones to Transmitter

### STEP 1

On your headphones, slide the **OFF**  **ON** switch to the ON position. The LED indicator should start flashing blue.

EN

### STEP 2

The transmitter is ON by default. If not, slide its **OFF**  **ON** switch to the ON position. The LED indicator should start flashing blue.

### STEP 3

Keep the headphones close to the transmitter; they should connect within 3-5 seconds. Once connected, both the headphones' and the transmitter's LED indicators will turn solid blue.

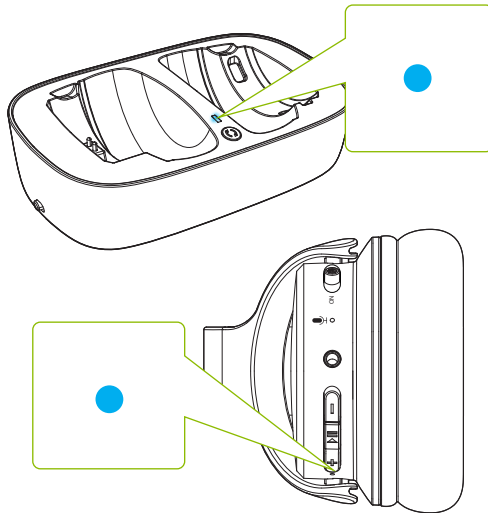

## Setting Up Your TV (For optical connections only)

If you connected to your TV via the optical OUT or "OPT OUT" port, you'll need to configure your TV settings before you'll receive audio.

EN

### STEP 1

Using your TV's remote control, press the SETTINGS button and navigate to the AUDIO tab within the settings menu. (Please note that there may be differences in the setting names depending on your brand of TV).

### STEP 2

Proceed to AUDIO OUTPUT and select "OPTICAL OUT / DIGITAL OUT". Many TVs will do this automatically; skip this step as needed.

### STEP 3

Set Audio Output format to "PCM / STEREO" ON or "DOLBY" OFF.

If you're having trouble finding these settings, you can scan the QR code correlating to your TV's brand OR visit [avantree.com/ensemble/tv-audio-settings](http://avantree.com/ensemble/tv-audio-settings) for a more detailed guide.



LG



SONY



SAMSUNG

*NOTE1: Some smart TVs automatically reset their settings after system updates. Make sure your audio output / input format is set to "PCM" and NOT "AUTO" or "DOLBY."*

*NOTE2: When using Netflix or Amazon Prime, you may need to start the movie / show before changing the audio settings to "PCM."*

## Advanced Features

### Adding a Second Pair of Headphones

You can add a second pair of Ensemble headphones (AS50) to your setup while maintaining low latency.

EN

#### STEP 1

Make sure your original Ensemble headphones & transmitter have connected.

#### STEP 2

On your transmitter, press & hold the  button until the LED indicator flashes red & blue.

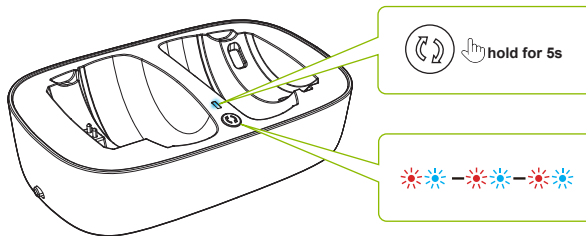

#### STEP 3

Turn on your second pair of AS50 headphones, then press & hold the  button until the LED indicator flashes red & blue.

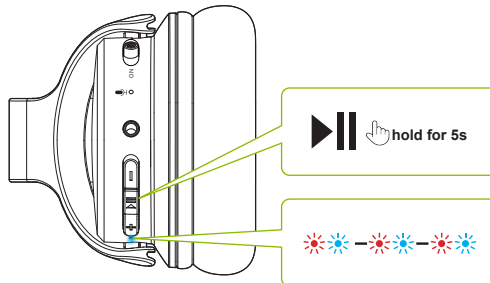

**STEP 4**

Once connected, the headphones' & transmitter's LED indicators will turn solid blue.

For subsequent use, please turn the original pair of Ensemble headphones on first. Once that's connected to the transmitter, you can turn on your second pair of AS50 headphones and wait for a few seconds. If it fails to reconnect, press the ►|| button once to activate reconnection.

To purchase AS50 headphones, scan the QR code

**Using the Headphones with Your Phone/Tablet****STEP 1**

Turn OFF or unplug the transmitter.

**STEP 2**

Turn on the headphones and press & hold the ►|| button until the LED indicator flashes red & blue.

**STEP 3**

Turn on your audio source's Bluetooth and select "Avantree AS50" from the Bluetooth menu.

## Charging the Headphones

Place the headphones on the charging dock in order to charge. The charging dock's LED will turn red while charging and green once charging is complete.

EN

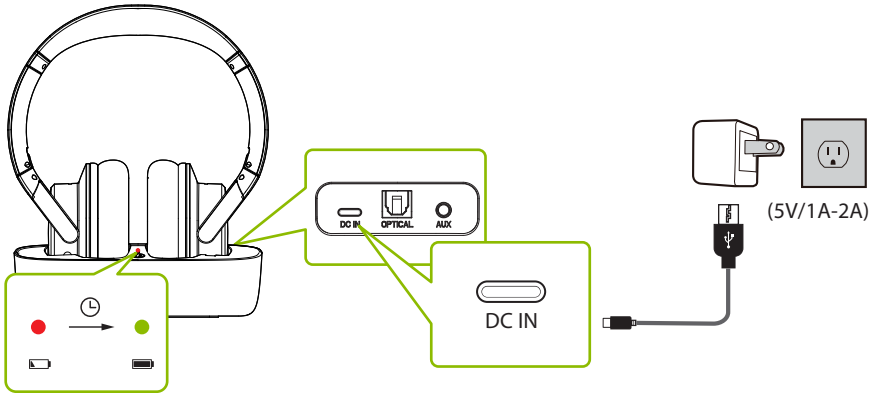

You can also charge the headphones through its power port using a charging cable. A solid red light indicates that charging is in progress; once the light turns off, your headphones will be at full battery. It typically takes 3 hours to fully charge.

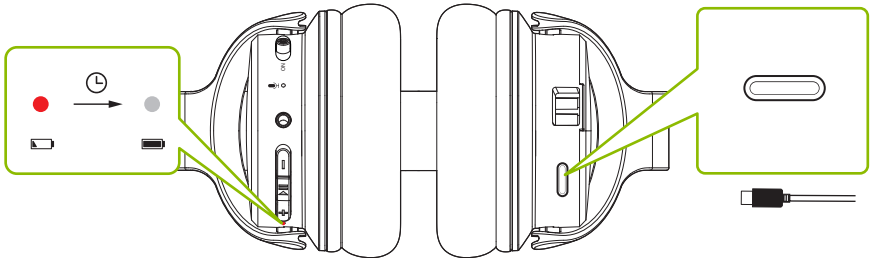

## Specifications

### Transmitter

EN

Bluetooth version	v5.0
Frequency response	20Hz - 20KHz
Operating range	Up to 100ft / 30m
Bluetooth profiles	HFP v1.7, AVRCP v1.5, A2DP v1.3
Supported audio codecs	aptX-LL, aptX, FastStream, SBC

### Headphones

Bluetooth version	v5.0
Frequency response	20Hz-20KHz
Bluetooth profiles	HSP v1.2, HFP v1.6, AVRCP v1.0, A2DP v1.0
Supported audio codecs	FastStream, SBC
Battery life	Up to 35 hours
Impedance	32Ω
Net weight	234g
Earpads inner size	55±1.5 * 43±1.5 * 15±1.5mm



## FAQ

Below are some of the most common questions people have during setup.

### **I have a Samsung / LG TV. Why are my headphones failing to reconnect to the transmitter?**

Samsung / LG smart TVs tend to pair with any Bluetooth devices they can find, which blocks the Avantree headphones from reconnecting to its transmitter. Try following the steps below in order to fix this:

**DENY the Device** - If a popup appears on your TV asking you to Allow or Deny / Block the device to connect to the TV, you MUST DENY / BLOCK the device from connecting.

**REMOVE the Device** - If your device is already paired with the TV, you'll need to remove the device in your TV's settings: SETTINGS > GENERAL > EXTERNAL DEVICE MANAGER>DEVICE CONNECTION MANAGER > DEVICE LIST > EDIT > Select all Avantree devices >DELETE.

Please note that the routing may differ based on your TV's brand / model.

**Turn OFF the TV** - Physically turn your TV OFF or pull the plug (the remote control does NOT turn the TV off; it places it into standby mode which still allows the TV to connect to devices).

### **Can I have audio through my TV's speakers and wireless headphones at the same time?**

This completely depends on whether or not your TV supports the ability to output audio to 2 devices simultaneously. You can try a few different methods to test if your TV is capable of this or not -- please refer to [avantree.com/ensemble/sound](https://www.avantree.com/ensemble/sound) for more details.

### **Why aren't I getting sound when watching Netflix / Amazon Prime?**

### **Why aren't my headphones connecting to the transmitter?**

.....

For answers to questions like these and for a full FAQ list, you can visit [avantree.com/support/ensemble](https://www.avantree.com/support/ensemble), or you can contact us directly for additional assistance.

## Contact Us

**Support Tickets**[avantree.com/submit-a-ticket](https://avantree.com/submit-a-ticket)

EN

**Support Email**[support@avantree.com](mailto:support@avantree.com)**USA / CA**

+1800 232 2078 (9am-6pm PST, Mon-Fri )

**UK**

+44 20 8068 2023 (9am-6pm, GMT, Mon-Sat)

**DE**

+49 32221097297 (11am-9pm, CET, Mon-Sat )

**FR**

+ 33 176340312 (11am-9pm, CET, Mon-Sat )

**IT**

+39 06 9480 3330 (9am-6pm, CET, Mon-Sat )

**ES**

+ 34 931786261 (9am-6pm, CET, Mon-Sat )

**AU**

+ 61 2 8310 9897 (11am-7pm, AEST, Mon-Fri)

**FAQ**[avantree.com/support/ensemble](https://avantree.com/support/ensemble)**Video Guide**[avantree.com/ensemble/video](https://avantree.com/ensemble/video)**Product Registration**[avantree.com/product-registration](https://avantree.com/product-registration)

## Video Anleitung

Möchten Sie lieber ein Video-Tutorial anschauen? Scannen Sie den QR-Code unten oder besuchen Sie [avantree.com/ensemble/video](https://avantree.com/ensemble/video) für eine Anleitung Schritt für Schritt.

DE



## Buchen Sie einen Termin



Sie können auch einen 1-zu-1-Einrichtungstermin mit einem unserer Support-Mitarbeiter unter [avantree.com/book-a-call](https://avantree.com/book-a-call).

# Inhaltsübersicht

<b>Verpackungsinhalt</b> .....	19
<b>Produkteinführung</b> .....	20
Produktübersicht .....	20
Tastenfunktionen .....	21
LED Anzeige .....	21
<b>Verwendung für TV-Wiedergabe</b> .....	22
Anschluss des Senders an Ihr Fernsehgerät .....	22
Option 1 - Optischer Anschluss (empfohlen) .....	22
Option 2 - AUX-Anschluss 3,5 mm .....	23
Option 3 – RCA-Anschluss .....	23
Anschließen der Kopfhörer an den Sender .....	24
Einrichten des Fernsehers (nur bei optischem Anschluss) .....	25
<b>Erweiterte Funktionen</b> .....	26
Hinzufügen eines 2. Kopfhörerpaars .....	26
Verwendung der Kopfhörer mit Ihrem Telefon / Tablet .....	27
<b>Aufladen der Kopfhörer</b> .....	28
<b>Technische Daten</b> .....	29
<b>FAQ</b> .....	30
<b>Kontakt</b> .....	31

## Verpackungsinhalt

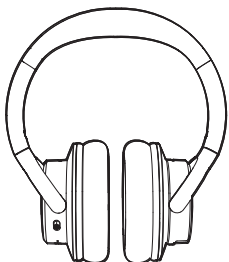

Kopfhörer

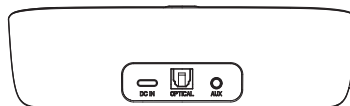

Sender / Ladestation

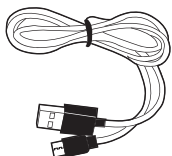

Stromkabel für  
den Sender

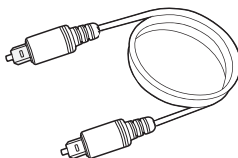

Optisches Audiokabel

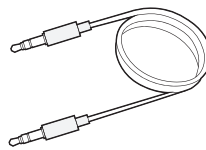

AUX-Audiokabel 3,5 mm

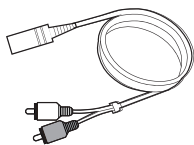

AUX auf RCA  
Adapter 3,5mm

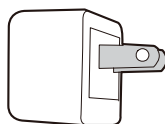

USB-Ladegerät

Informationen zum Ansehen und Kauf von Ensemble-Zubehör  
finden Sie unter [avantree.com/ensemble/accessories](https://avantree.com/ensemble/accessories)



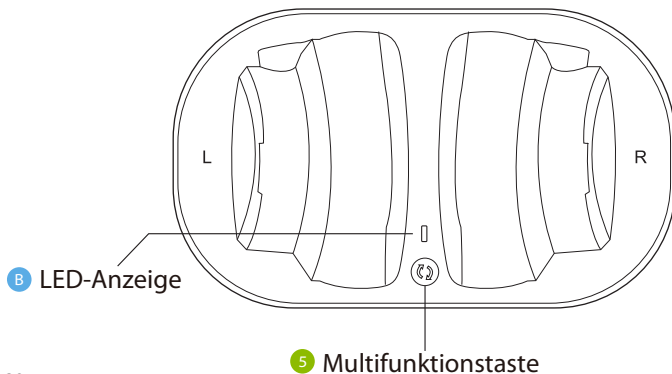
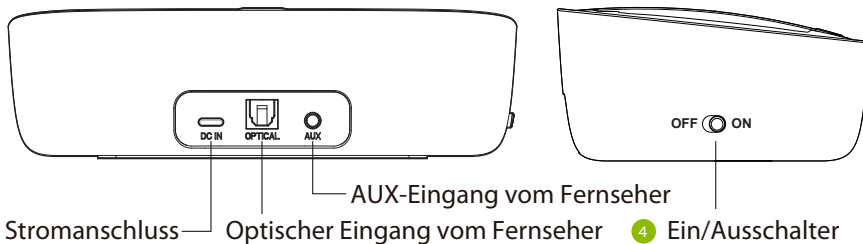
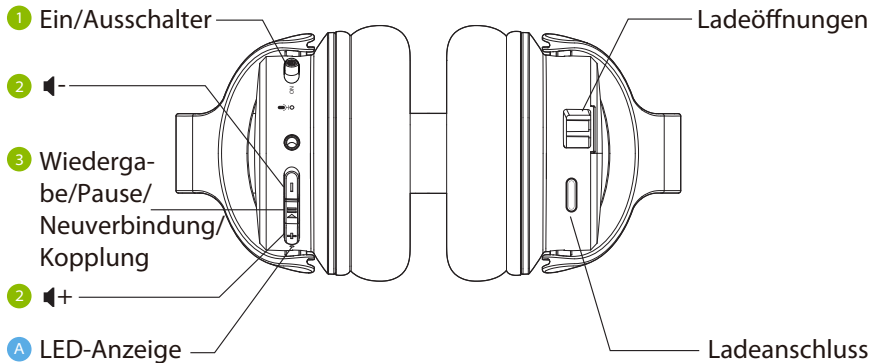

# Produkteinführung

## Produktübersicht

DE



## Tastenfunktionen

Nr.	Tasten	Funktionen
1	ON  OFF	Schalter zum Ein-/Ausschalten der Kopfhörer
2	+ / -	Zum Einstellen der Lautstärke drücken oder halten
3		Wenn sich die Kopfhörer nicht automatisch mit dem Sender verbinden, drücken Sie einmal, um die Wiederverbindung zu aktivieren
		Die Taste 5 Sekunden lang gedrückt halten, um die Kopfhörer in den Paring-Modus zu versetzen
		Einmal drücken, um den Ton abzuspielen/anzuhalten (bei separater Verwendung mit Telefon/Tablet)
4	OFF  ON	Schalter zum Ein- / Ausschalten des Senders
5		Die Taste 5 Sekunden lang gedrückt halten, um den Sender in den Kopplungsmodus zu bringen

## LED Indicators

Nr.	Anzeige	Status
A	Blaues Blinken	Betriebsbereit
	Blaues Leuchten	Verbunden
	Rotes & blaue Blinken	Kopplungsmodus
	Rotes Blinken	Niedriger Akkustand
	Rotes Leuchten	Im Lademodus
	Aus	Vollständig geladen
B	Blaues Blinken	Betriebsbereit
	Blaues Leuchten	Verbunden
	Rotes & blaue Blinken	Kopplungsmodus
	Rotes Leuchten	Im Lademodus
	Grünes Leuchten	Vollständig geladen

## Verwendung für TV-Wiedergabe

### Anschluss des Senders an Ihr Fernsehgerät

DE

Der Sender muss an eine Stromquelle angeschlossen sein, um zu funktionieren. Schließen Sie ihn über den mitgelieferten USB-Adapter und das Netzkabel an eine Steckdose in der Nähe an.

Für den Anschluss an die Audioausgänge des Fernsehers können Sie zwischen 3 verschiedenen Optionen wählen: optisch, AUX 3,5 mm oder RCA-Adapter.

#### OPTION 1 - Optischer Anschluss (empfohlen)

Stecken Sie das mitgelieferte optische Audiokabel in den DIGITAL AUDIO OUT(OPTICAL)-Anschluss des Fernsehers und dann das andere Ende in den optischen Anschluss des Senders.

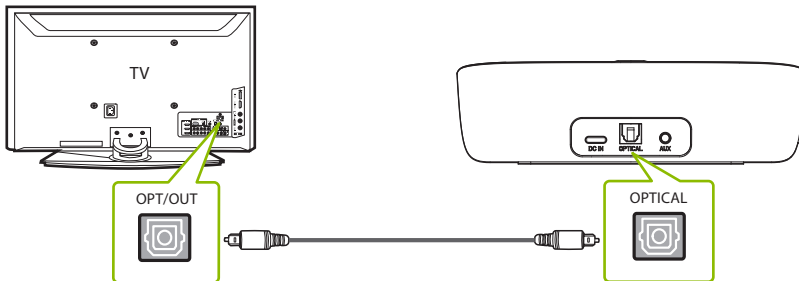

*HINWEIS: Die meisten Fernsehgeräte unterstützen nur einen digitalen Ausgang. Wenn also der HDMI ARC-Anschluss Ihres Fernsehers verwendet wird, wird der optische Anschluss deaktiviert. Alternativ ziehen Sie den HDMI ARC raus oder schließen Sie den Sender über RCA/AUX an.*



**OPTION 2** - AUX-Anschluss 3,5 mm

Stecken Sie das mitgelieferte AUX-Audiokabel 3,5mm in den AUX-Ausgang 3,5mm des Fernsehgeräts und dann das andere Ende in den AUX-Anschluss 3,5mm des Senders.

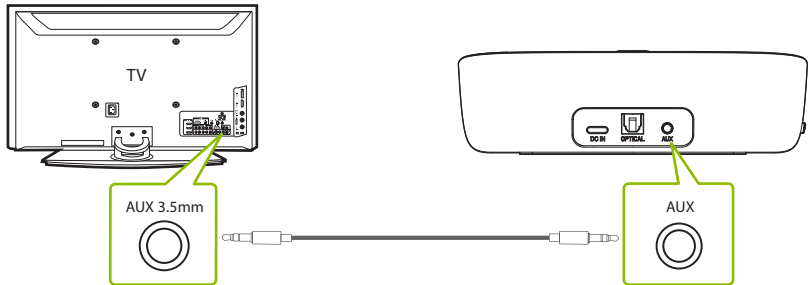
**OPTION 3** - RCA-Anschluss

Verbinden Sie den mitgelieferten RCA-Adapter mit dem AUX-Audiokabel 3,5 mm. Stecken Sie die roten und weißen RCA-Stecker in die "AUDIO OUT"-Anschlüsse des Fernsehgeräts und stecken Sie dann das andere Ende in den AUX-Anschluss 3,5 mm des Senders.

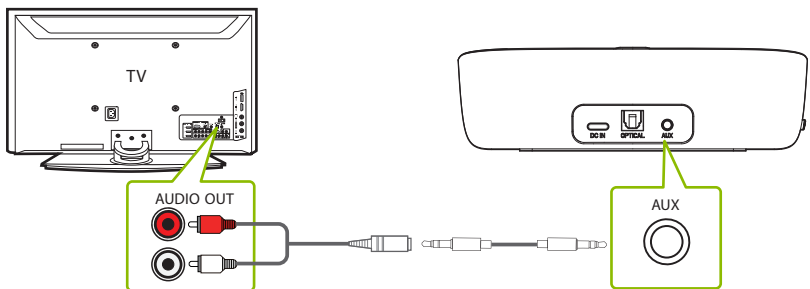

## Anschließen der Kopfhörer an den Sender

### SCHRITT 1

Stellen Sie den **OFF** (○) **ON** Schalter an Ihrem Kopfhörer auf ON, die LED-Anzeige sollte blau blinken.

DE

### SCHRITT 2

Der Sender ist standardmäßig auf ON gestellt, falls nicht, stellen Sie den **OFF** (○) **ON** Schalter des Senders auf ON, die LED-Anzeige sollte blau blinken.

### SCHRITT 3

Halten Sie beide Geräte nahe beieinander. Innerhalb von 3-5 Sekunden werden sie verbunden, sowohl Kopfhörer als auch Senderanzeige leuchten dann blau.

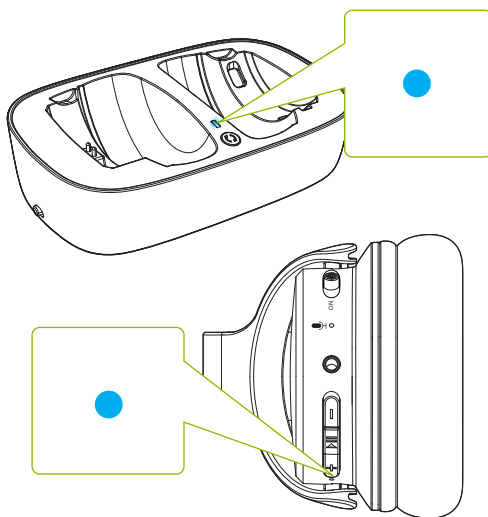

## Einrichten des Fernsehers (nur bei optischem Anschluss)

Wenn Sie Ihr Fernsehgerät über den optischen Ausgang oder den "OPT OUT"-Anschluss angeschlossen haben, müssen Sie die Einstellungen Ihres Fernsehgeräts konfigurieren, bevor Sie den Ton empfangen können.

### SCHRITT 1

Drücken Sie auf der Fernbedienung Ihres Fernsehers die Taste SETTINGS und navigieren Sie im Einstellungs Menü zur Registerkarte AUDIO. (Bitte beachten Sie, dass die Bezeichnungen der Einstellungen je nach Fernsehmarke unterschiedlich sein können).

### SCHRITT 2

Gehen Sie zu AUDIO OUTPUT und wählen Sie "OPTICAL OUT / DIGITAL OUT". Bei vielen Fernsehgeräten geschieht dies automatisch; überspringen Sie diesen Schritt bei Bedarf.

### SCHRITT 3

Stellen Sie das Audio-Ausgangsformat auf "PCM / STEREO" ON oder "DOLBY" OFF.

Wenn Sie Probleme haben, diese Einstellungen zu finden, können Sie den QR-Code scannen, der der Marke Ihres Fernsehers entspricht ODER besuchen Sie [avantree.com/ensemble/tv-audio-settings](http://avantree.com/ensemble/tv-audio-settings) für eine detaillierte Anleitung.



LG



SONY



SAMSUNG

*HINWEIS 1: Smart-TVs setzen ihre Einstellungen automatisch nach System-Updates zurück. Stellen Sie sicher, dass Ihr Audio-Ausgabe- / Eingabeformat auf "PCM" und NICHT auf "AUTO" oder "Dolby" eingestellt ist.*

*HINWEIS 2: Wenn Sie Netflix oder Amazon Prime verwenden, müssen Sie möglicherweise den Film / die Show starten, bevor Sie die Audio-Einstellungen auf "PCM" ändern.*

## Erweiterte Funktionen

### Hinzufügen eines 2. Kopfhörerpaars

DE

Sie können ein zweites Paar Ensemble-Kopfhörer (AS50) zu Ihrem Gerät hinzufügen und dabei eine niedrige Latenz beibehalten.

#### SCHRITT 1

Vergewissern Sie sich, dass Ihre Original-Ensemble-Kopfhörer und der Sender angeschlossen sind.

#### SCHRITT 2

Drücken und halten Sie die  Taste auf Ihrem Sender, bis die LED-Anzeige rot & blau blinkt.

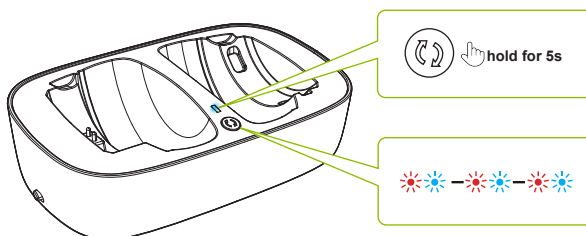

#### SCHRITT 3

Schalten Sie Ihr zweites Paar AS50-Kopfhörer ein und halten Sie die  Taste gedrückt, bis die LED-Anzeige rot und blau blinkt.

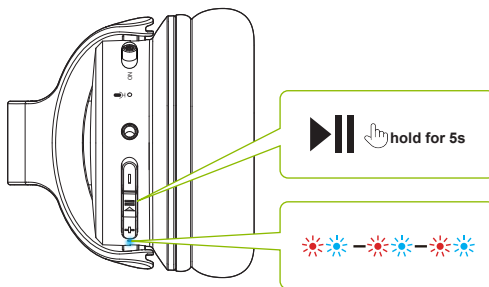

## SCHRITT 4

Sobald die Verbindung hergestellt ist, leuchten die LED-Anzeigen der Kopfhörer und des Senders durchgehend blau.

Für die spätere Verwendung schalten Sie bitte zuerst das Originalpaar der Ensemble-Kopfhörer ein. Sobald dieser mit dem Sender verbunden ist, können Sie Ihr zweites Paar AS50-Kopfhörer einschalten und ein paar Sekunden lang warten. Wenn die Verbindung nicht wiederhergestellt werden kann, drücken Sie die ►|| Taste einmal, um die Verbindung wiederherzustellen.

Um AS50 Kopfhörer zu kaufen, scannen Sie den QR-Code



## Verwendung der Kopfhörer mit Ihrem Telefon / Tablet

### SCHRITT 1

Schalten Sie den Sender aus oder ziehen Sie den Netzstecker.

### SCHRITT 2

Schalten Sie den Kopfhörer ein, drücken Sie die ►|| Taste und halten Sie sie gedrückt, bis die LED-Anzeige rot und blau blinkt.

### SCHRITT 3

Schalten Sie das Bluetooth Ihrer Audioquelle ein und wählen Sie "Avantree AS50" aus dem Bluetooth-Menü.

## Aufladen der Kopfhörer

Setzen Sie die Kopfhörer zum Aufladen auf die Ladestation. Die LED der Ladestation leuchtet während des Ladevorgangs rot und nach Abschluss des Ladevorgangs grün.

DE

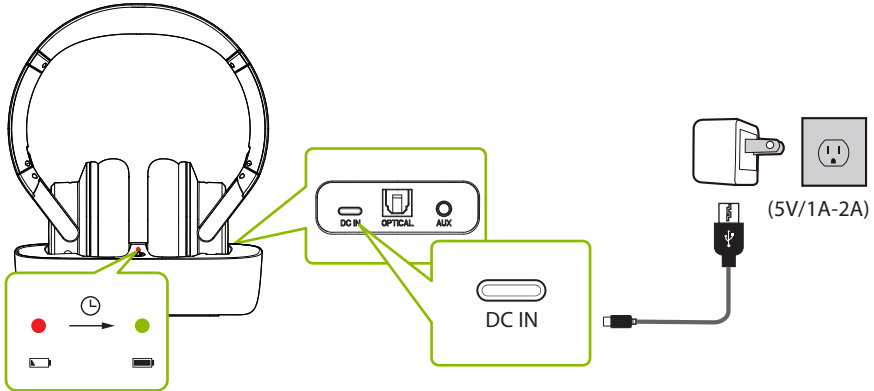

Sie können die Kopfhörer auch mit einem Ladekabel über den Netzanschluss aufladen. Ein durchgehendes rotes Licht zeigt an, dass der Ladevorgang läuft; sobald das Licht erlischt, ist die Batterie Ihrer Kopfhörer voll aufgeladen. Normalerweise dauert es 3 Stunden, bis der Akku vollständig aufgeladen ist.

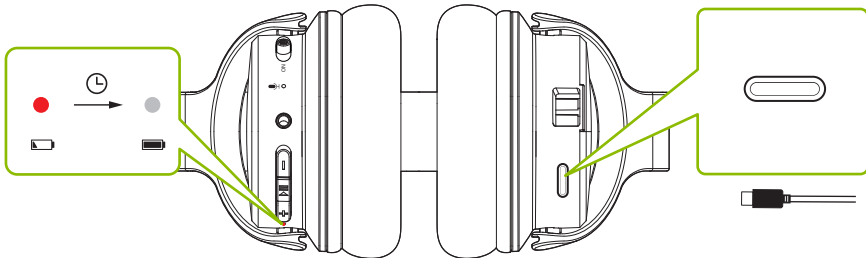

## Technische Daten

### Sender

Bluetooth-Version	V5.0
Frequenzbereich	20Hz - 20KHz
Reichweite	Up to 100ft / 30m
Bluetooth-Profile	HFP v1.7, AVRCP v1.5, A2DP v1.3
Audio-Codec Unterstützung	aptX-LL, aptX, FastStream, SBC

### Kopfhörer

Bluetooth-Version	V5.0
Frequenzbereich (Hz)	20Hz-20KHz
Bluetooth-Profile	HSP v1.2, HFP v1.6, AVRCP v1.0, A2DP v1.0
Audio-Codec-Unterstützung	FastStream, SBC
Akkulaufzeit	Bis zu 35 Stunden
Impedanz	32Ω
Nettogewicht	234g
Ohrpolster-Innengröße	55±1.5 * 43±1.5 * 15±1.5mm

## FAQ

Nachfolgend finden Sie einige der am häufigsten gestellten Fragen während der Einrichtung.

### **Ich habe einen Samsung/LG-Fernseher. Warum lassen sich meine Kopfhörer nicht mehr mit dem Transmitter verbinden?**

Samsung- oder LG-Smart-TVs neigen dazu, sich mit allen verfügbaren Bluetooth-Geräten zu verbinden, was dazu führt, dass die Avantree-Kopfhörer keine Verbindung zum Transmitter herstellen können. Versuchen Sie bitte die folgenden Schritte, um dieses Problem zu beheben:

**Das Gerät verweigern** - Wenn ein Dialogfenster auf Ihrem Fernsehgerät erscheint, in dem Sie aufgefordert werden, die Verbindung des Geräts mit dem Fernsehgerät zuzulassen oder zu verweigern/zu blockieren, MÜSSEN Sie die Verbindung des Geräts verweigern/blockieren.

**Gerät ENTFERNEN** - Falls Ihr Gerät bereits mit dem Fernseher verbunden ist, müssen Sie das Gerät in den Einstellungen des Fernsehers entfernen:

EINSTELLUNGEN > ALLGEMEIN > EXTERNE GERÄTE-VERWALTUNG > GERÄTE-VERBINDUNGSMANAGER > GERÄTENLISTE > BEARBEITEN > Alle Avantree-Geräte auswählen > LÖSCHEN. Bitte beachten Sie, dass die genaue Vorgehensweise je nach Marke und Modell Ihres Fernsehers variieren kann.

**TV ausschalten** - Schalten Sie den Fernseher physisch aus oder ziehen Sie den Stecker (die Fernbedienung schaltet den Fernseher NICHT aus, sondern versetzt ihn nur in den Standby-Modus, wodurch der Fernseher immer noch mit Geräten verbunden bleiben kann).

### **Kann ich gleichzeitig Audio über die Lautsprecher meines Fernsehers UND über kabellose Kopfhörer empfangen?**

Wenn Sie den Ton sowohl über die Lautsprecher Ihres Fernsehers als auch über Ihre Kopfhörer gleichzeitig hören möchten, hängt dies davon ab, ob Ihr Fernseher die gleichzeitige Tonwiedergabe an zwei Quellen unterstützt. Dies steht in keinem Zusammenhang mit dem Transmitter. Der Transmitter empfängt den Ton von der Audioausgabe Ihres Fernsehers und überträgt ihn an Ihre kabellosen Kopfhörer oder Lautsprecher. Sie können verschiedene Methoden ausprobieren, um zu überprüfen, ob alles in Ordnung ist. Weitere Details finden Sie unter [avantree.com/ensemble/sound](https://avantree.com/ensemble/sound).

#### **1, Warum kein Ton beim Ansehen von Netflix/Amazon Prime?**

#### **2, Kopfhörer kann nicht mit dem Sender verbinden?**

.....

Für Antworten auf Fragen wie diese und eine vollständige Liste häufig gestellter Fragen (FAQs) können Sie [avantree.com/support/ensemble](https://avantree.com/support/ensemble) besuchen oder uns direkt kontaktieren, um zusätzliche Unterstützung zu erhalten.



## Kontaktieren Sie uns

**Support-Tickets**[avantree.com/submit-a-ticket](https://avantree.com/submit-a-ticket)**Support-E-Mail**[support@avantree.com](mailto:support@avantree.com)**USA / CA**

+1800 232 2078 (9am-6pm PST, Mon-Fri )

**UK**

+44 20 8068 2023 (9am-6pm, GMT, Mon-Sat)

**DE**

+49 32221097297 (11am-9pm, CET, Mon-Sat )

**FR**

+ 33 176340312 (11am-9pm, CET, Mon-Sat )

**IT**

+39 06 9480 3330 (9am-6pm, CET, Mon-Sat )

**ES**

+ 34 931786261 (9am-6pm, CET, Mon-Sat )

**AU**

+ 61 2 8310 9897 (11am-7pm, AEST, Mon-Fri)

**FAQ**[avantree.com/support/ensemble](https://avantree.com/support/ensemble)**Videoanleitung**[avantree.com/ensemble/video](https://avantree.com/ensemble/video)**Produktregistrierung**[avantree.com/product-registration](https://avantree.com/product-registration)

## Guide Video

Vous préférez un tutoriel vidéo? Scannez le code QR ci-dessous ou visitez [avantree.com/ensemble/video](https://avantree.com/ensemble/video) pour un guide étape par étape.

FR



## Prenez rendez-vous



Vous pouvez également réserver un rendez-vous d'assistance individuel avec l'un de nos agents de support via [avantree.com/book-a-call](https://avantree.com/book-a-call)

# Sommaire

<b>Contenu de la boîte</b> .....	34
<b>Introduction</b> .....	35
Vue d'ensemble .....	35
Boutons .....	36
Indicateurs LED .....	36
<b>Usage TV</b> .....	37
Connecter le transmetteur à votre TV .....	37
Option 1 – Port Optique (recommandé) .....	37
Option 2 – Port AUX 3.5mm .....	38
Option 3 – Port RCA .....	38
Connecter le casque au transmetteur .....	39
Réglage TV (pour connexion optique uniquement) .....	40
<b>Fonctions avancées</b> .....	41
Ajout d'un 2nd casque audio .....	41
Utiliser le casque avec votre téléphone/tablette .....	42
<b>Charge du casque</b> .....	43
<b>Spécifications</b> .....	44
<b>FAQ</b> .....	45
<b>Contactez-nous</b> .....	46

## Box Contents

FR

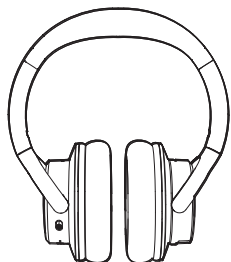

Casque audio

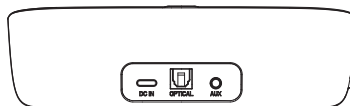

Émetteur / Station de charge

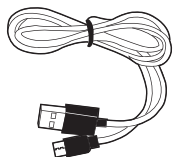

Câble d'alimentation pour émetteur

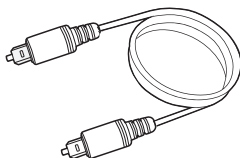

Câble audio optique

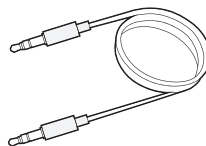

Câble audio auxiliaire 3,5 mm

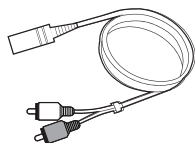

Adaptateur Aux 3,5 mm vers RCA

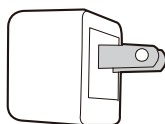

Chargeur USB



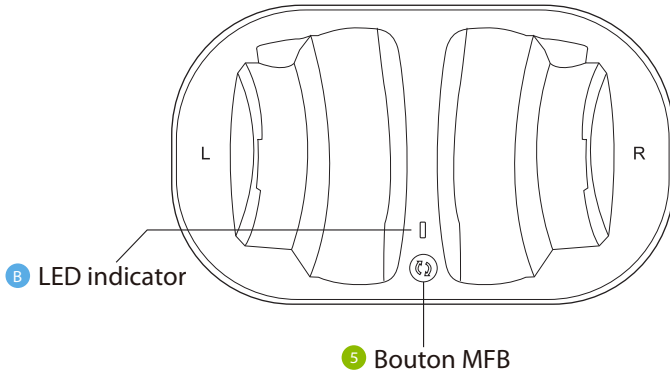
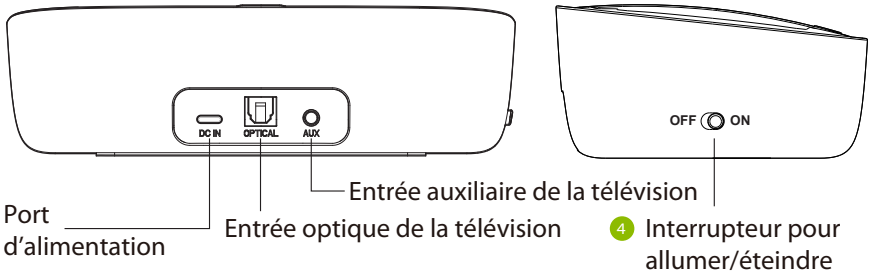
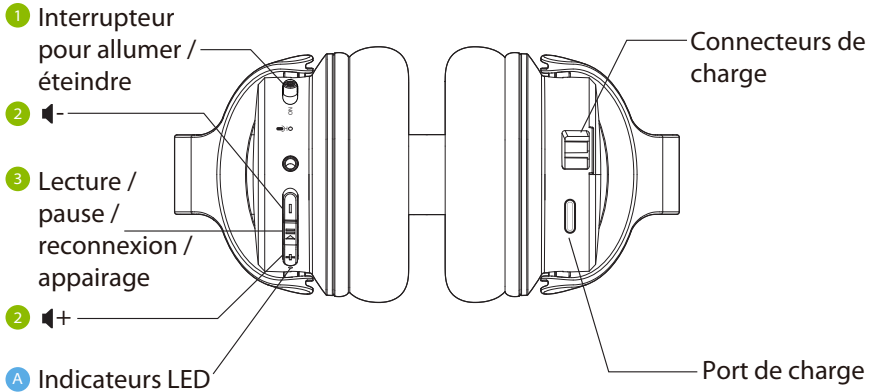

Pour voir et acheter des accessoires supplémentaires, visitez [avantree.com/ensemble/accessories](http://avantree.com/ensemble/accessories)

# Introduction

## Vue d'ensemble



## Boutons

NBr.	Boutons	Fonction
1	ON  OFF	Commutateur pour allumer/éteindre le casque (ON/OFF)
2	+ / -	Appuyez ou maintenez pour régler le volume
3		Si le casque ne parvient pas à se connecter automatiquement à l'émetteur, appuyez une fois pour activer la reconnexion
		Appuyez et maintenez enfoncé 5 sec. pour passer le casque en appairage
		Appuyez une fois pour lire / mettre en pause l'audio (si le casque est utilisé séparément avec un téléphone / une tablette)
4	OFF  ON	Switch to turn the transmitter on / off
5		Press & hold for 5 seconds to place the transmitter into pairing mode

## Indicateur LED

NBr.	Indicateurs	Statut
A	Bleu clignotant	En marche
	Bleu fixe	Connecté
	Clignotant rouge & bleu	En appairage
	Clignotant rouge	Batterie faible
	Rouge fixe	En charge
	Eteint	Charge terminée
B	Bleu clignotant	En marche
	Bleu fixe	Connecté
	Clignotant rouge & bleu	En appairage
	Rouge fixe	En charge
	Vert fixe	Charge terminée

## Usage TV

### Connecter le transmetteur à votre TV

L'émetteur doit être connecté à une source d'alimentation pour fonctionner. Connectez-le à une prise murale à proximité via l'adaptateur USB et le câble d'alimentation fournis.

En le connectant aux ports de sortie audio du téléviseur, vous pouvez choisir l'une des 3 options différentes: optique, aux 3,5 mm ou via adaptateur RCA.

#### OPTION 1 - Port optique (recommandé)

Branchez le câble audio optique fourni dans le port DIGITAL AUDIO OUT(OP-TICAL) du téléviseur, puis branchez l'autre extrémité dans le port optique de l'émetteur.

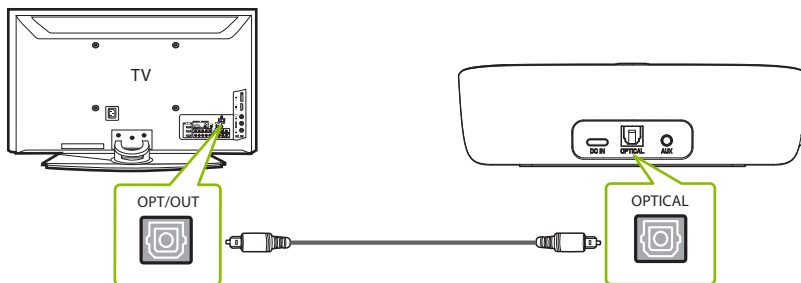

*NOTE: La plupart des TV n'ont qu'1 sortie numérique. Si l'HDMI ARC de votre TV est utilisé, le port optique sera désactivé. Solutions alternatives, débrancher le câble HDMI ARC ou connecter le transmetteur via RCA/AUX.*

**OPTION 2** - Port AUX 3.5mm

Branchez le câble audio AUX 3,5 mm fourni dans le port de sortie AUX 3,5 mm du téléviseur, puis branchez l'autre extrémité dans le port AUX 3,5 mm de l'émetteur.

FR

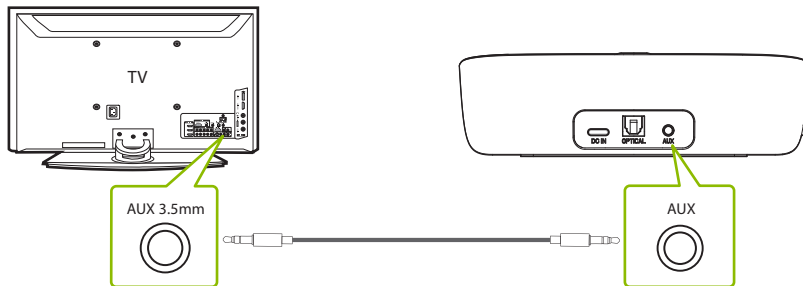
**OPTION 3** - Port RCA

Connectez l'adaptateur RCA fourni au câble audio AUX 3,5 mm. Branchez les connecteurs RCA rouge et blanc dans les ports "AUDIO OUT" du téléviseur, puis branchez l'autre extrémité dans le port AUX 3,5 mm de l'émetteur.

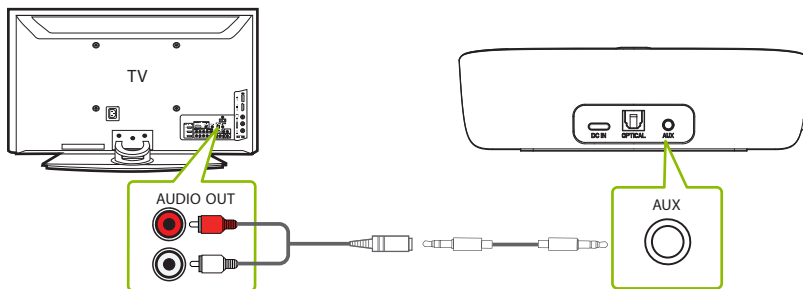



## Connecter le casque au transmetteur

### Étape 1

Sur votre casque, glisser l'interrupteur ON/OFF sur ON, le voyant LED doit clignoter en bleu.

### Étape 2

L'émetteur est en position ON par défaut, sinon glisser son interrupteur ON/OFF sur ON, le voyant LED doit clignoter en bleu.

### Étape 3

Gardez-les à proximité, ils se connecteront dans 3 à 5 secondes, les LED de l'écouteur et de l'émetteur deviennent bleus.

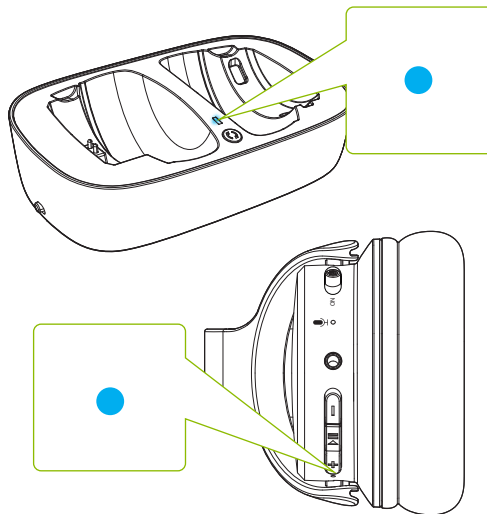

## Réglage TV (connexion optique uniquement)

Si vous êtes connecté à votre téléviseur via la sortie optique "OPT OUT", vous devrez certainement configurer les paramètres audio de votre TV.

### Etape 1

Avec la télécommande de votre TV, appuyez sur le bouton PARAMÈTRES et accédez à l'onglet AUDIO (Il peut y avoir des différences dans les noms des paramètres en fonction de votre modèle de TV).

### Etape 2

Allez sur "SORTIE AUDIO", sélectionnez "SORTIE OPTIQUE / NUMERIQUE". La majorité des TV le font automatiquement, sauter l'étape si besoin.

### Etape 3

Réglez le format de sortie audio sur "PCM / STEREO" ON ou "DOLBY" OFF.

En cas de difficultés pour trouver ces paramètres, scannez le code QR correspondant à la marque de votre téléviseur OU visitez [avantree.com/ensemble/tv-audio-settings](http://avantree.com/ensemble/tv-audio-settings) pour un guide plus détaillé.



LG



SONY



SAMSUNG

*NOTE 1 : Certaines SmartTV se réinitialisent automatiquement après une mise à jour, vérifiez si le format de sortie/entrée audio est bien réglé sur PCM au lieu d'AUTO, or Dolby.*

*NOTE 2: Lorsque vous utilisez Netflix ou Amazon Prime, vous devrez peut-être démarrer le film/l'émission avant de modifier les paramètres audio sur "PCM."*

## Fonctions avancées

### Ajout d'un 2ième casque audio

Vous pouvez ajouter une deuxième paire d'écouteurs Ensemble (AS50) à votre configuration tout en profitant d'une faible latence.

FR

#### Etape 1

Assurez-vous que vos écouteurs et l'émetteur d'origine sont connectés.

#### Etape 2

Sur votre émetteur, maintenez enfoncée le bouton  jusqu'à ce que le voyant LED clignote en rouge et bleu.

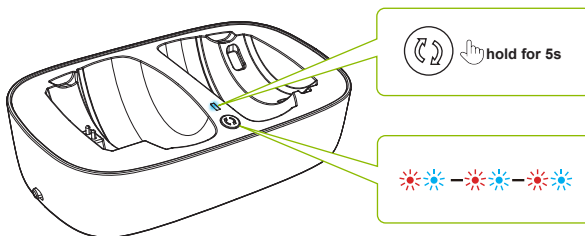

#### Etape 3

Allumez votre 2ième paire d'écouteurs AS50, puis maintenez enfoncée le bouton  jusqu'au voyant LED clignotant rouge et bleu.

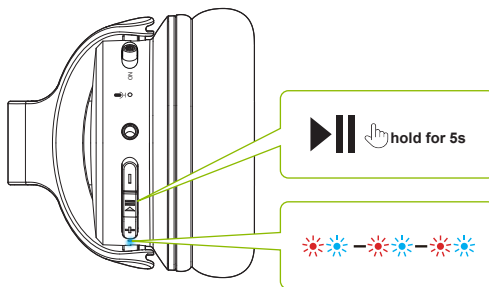

## Etape 4

Une fois connectés, les voyants LED du casque et de l'émetteur seront bleus fixes.

FR

Ultérieurement, allumez d'abord les écouteurs d'origine. Une fois connectés à l'émetteur, allumez les écouteurs AS50 restants et patientez quelques secondes. S'ils ne se reconnectent pas, appuyez sur ►|| une fois pour lancer la reconnexion.

Pour acheter un casque AS50 supplémentaire, scanner le code QR ci-contre



## Utiliser le casque avec votre téléphone/tablette

### Etape 1

Éteignez ou débranchez l'émetteur.

### Etape 2

Allumez le casque, appuyez et maintenez le bouton ►|| jusqu'à ce que le voyant LED clignote en rouge et bleu.

### Etape 3

Activez le Bluetooth de votre téléphone et sélectionnez "Avantree AS50" dans le menu Bluetooth.

## Charge du casque

Pour recharger votre casque, placez-le sur l'émetteur/ station de charge. La LED de la station deviendra rouge pendant la charge et verte une fois la charge terminée.

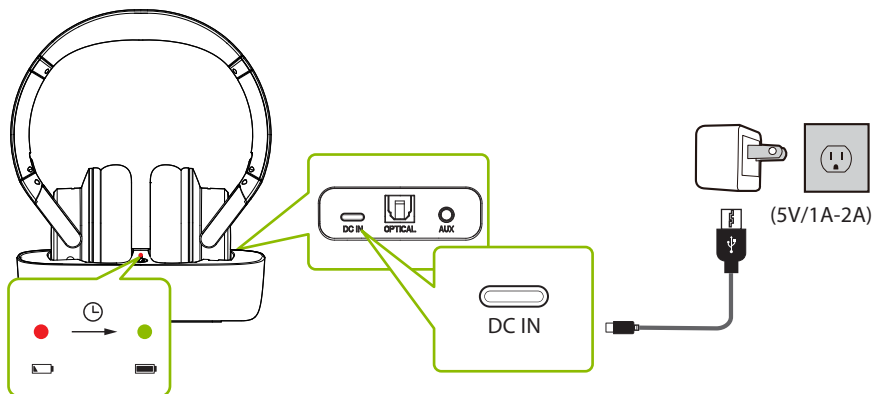

Vous pouvez également recharger le casque via son port USB à l'aide d'un câble de charge. Un voyant rouge fixe indique que la charge est en cours ; une fois la lumière éteinte, il sera rechargé. Habituellement, il faut environ 3 heures pour une charge complète.

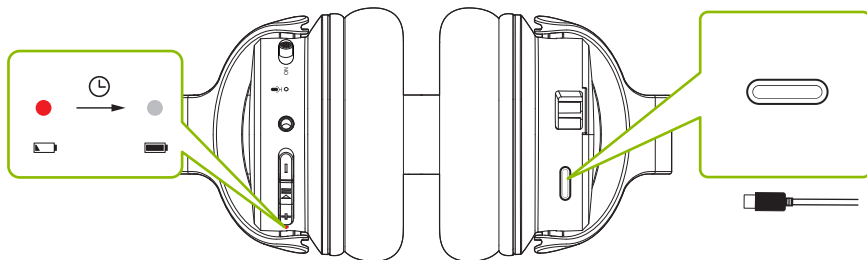

# Spécifications

## Transmetteur

Version Bluetooth	V5.0
Fréquence de réponse	20Hz - 20KHz
Portée	Jusqu'à 30m
Profils Bluetooth	HFP v1.7, AVRCP v1.5, A2DP v1.3
Codecs audio	aptX-LL, aptX, FastStream, SBC

FR

## Casque audio

Version Bluetooth	V5.0
Fréquences (Hz)	20Hz-20KHz
Profils Bluetooth	HSP v1.2, HFP v1.6, AVRCP v1.0, A2DP v1.0
Codecs audio	FastStream, SBC
Autonomie	Up to 35 hours
Impédance	32Ω
Poids	234g
Taille intérieure des coussinets	55±1.5 * 43±1.5 * 15±1.5mm

## FAQ

Vous trouverez ci-dessous certaines des questions les plus fréquemment posées par les utilisateurs.

### **J'ai un téléviseur Samsung/LG. Pourquoi mes écouteurs ne parviennent-ils pas à se reconnecter à l'émetteur?**

Les SmartTV Samsung / LG ont tendance à se coupler avec tous les appareils Bluetooth qu'ils trouvent, ce qui empêche le casque Avantree de se reconnecter à son émetteur. Essayez les étapes ci-dessous pour résoudre ce problème:

**REFUSER l'association** - Si une popup apparaît sur votre téléviseur vous demandant d'autoriser ou de refuser/bloquer une connexion, validez REFUSER/BLOQUER la connexion.

**RETIREZ l'appareil** - Si votre appareil est déjà associé avec le téléviseur, supprimez-le dans ses paramètres : RÉGLAGES > GÉNÉRAL > GESTIONNAIRE D'APPAREILS EXTERNES > CONNEXION > LISTE D'APPAREILS > MODIFIER > Sélectionner tous les appareils Avantree > SUPPRIMER. Notez que le chemin peut différer suivant la marque/ modèle de votre téléviseur.

**Eteindre votre TV** - Éteignez physiquement votre téléviseur ou débranchez la prise (la télécommande n'éteint PAS le téléviseur, elle le place en veille ce qui permet toujours au téléviseur de se connecter aux appareils).

### **Puis-je avoir du son via les enceintes TV ET mes écouteurs sans fil en même temps ?**

Si vous souhaitez obtenir du son sur les haut-parleurs de votre téléviseur ET sur vos écouteurs en même temps, cela DÉPEND de la capacité du téléviseur à prendre en charge une sortie son simultanée vers deux équipements. Ce n'est PAS lié à notre émetteur car il reçoit le son de la sortie de votre téléviseur et le diffuse sur vos appareils sans fil. Pour plus de détails, visitez ce lien [avantree.com/support/ensemble](https://www.avantree.com/support/ensemble)

### **Pourquoi je n'ai aucun son en regardant Netflix/Amazon Prime? Mes écouteurs ne peuvent pas se connecter à l'émetteur, que faire?**

.....

Pour plus de réponses à vos questions et pour une liste complète de FAQ, visitez [avantree.com/support/ensemble](https://www.avantree.com/support/ensemble) ou contactez-nous directement pour une assistance supplémentaire.

## Nous contacter

 **Tickets de support technique** [avantree.com/submit-a-ticket](https://avantree.com/submit-a-ticket)

 **Email de support technique** [support@avantree.com](mailto:support@avantree.com)

FR

 **USA / CA** +1800 232 2078 (9am-6pm PST, Mon-Fri )  
**UK** +44 20 8068 2023 (9am-6pm, GMT, Mon-Sat)  
**DE** +49 32221097297 (11am-9pm, CET, Mon-Sat )  
**FR** + 33 176340312 (11am-9pm, CET, Mon-Sat )  
**IT** +39 06 9480 3330 (9am-6pm, CET, Mon-Sat )  
**ES** + 34 931786261 (9am-6pm, CET, Mon-Sat )  
**AU** + 61 2 8310 9897 (11am-7pm, AEST, Mon-Fri)

 **FAQ** [avantree.com/support/ensemble](https://avantree.com/support/ensemble)

 **Guide vidéo** [avantree.com/ensemble/video](https://avantree.com/ensemble/video)

 **Enregistrement garantie produit** [avantree.com/product-registration](https://avantree.com/product-registration)



## Videoguida

Preferisci guardare un video tutorial? Scansiona il codice QR qui sotto o visita [avantree.com/ensemble/video](https://avantree.com/ensemble/video) per una guida dettagliata.



## Prenotare un Appuntamento



Puoi anche prenotare un appuntamento di installazione 1 a 1 con uno dei nostri agenti di supporto su [avantree.com/book-a-call](https://avantree.com/book-a-call)

# Indice dei Contenuti

<b>Contenuto della confezione</b> .....	49
<b>Introduzione al Prodotto</b> .....	50
Panoramica del Prodotto .....	50
Tasti .....	51
Indicatori LED .....	51
<b>Uso con la TV</b> .....	52
Collegare il Trasmettitore alla TV .....	52
Opzione 1 - Uscita Ottica(raccomandata) .....	52
Opzione 2 - Uscita AUX 3.5mm .....	53
Opzione 3 - Uscita RCA .....	53
Collegare le Cuffie al Trasmettitore .....	54
Impostazione della TV (solo per connessione Ottica) .....	55
<b>Funzionalità Avanzate</b> .....	56
Aggiungere un Secondo Paio di Cuffie .....	56
Usare le Cuffie con Telefono/Tablet .....	57
<b>Ricarica delle cuffie</b> .....	58
<b>Specifiche</b> .....	59
<b>Domande frequenti</b> .....	60
<b>Contattaci</b> .....	61

## Box Contents

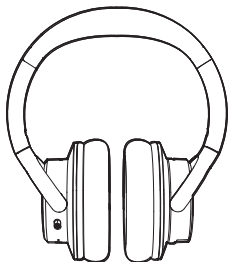

Cuffie

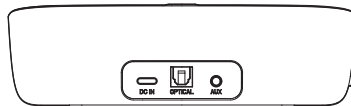

Trasmettitore/Base di Ricarica

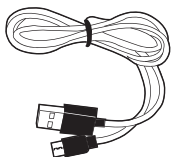

Cavo di Alimentazione  
per il Trasmettitore

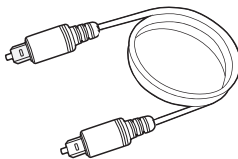

Cavo Audio Ottico

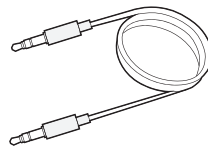

Cavo Audio AUX  
da 3.5mm

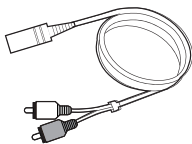

Adattatore da AUX  
da 3.5mm a RCA

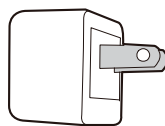

Caricatore USB



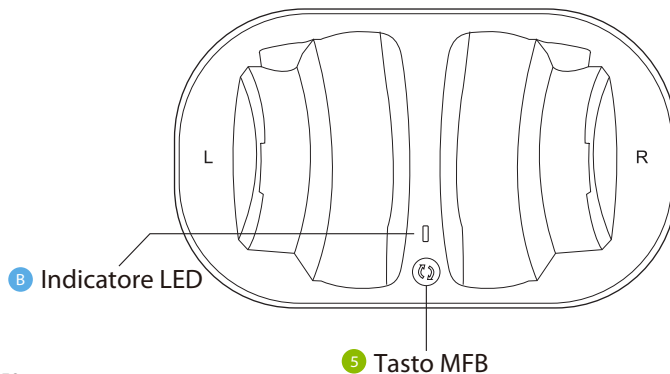
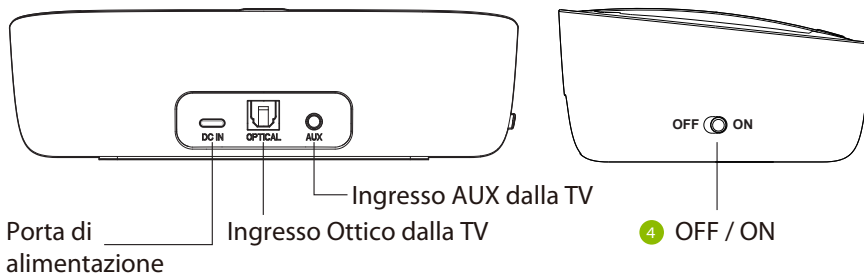
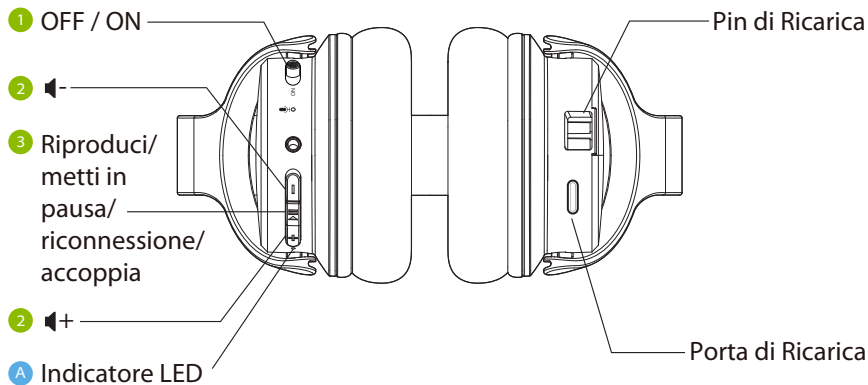

Per visualizzare e acquistare gli accessori Ensemble, visitare il sito [avantree.com/ensemble/accessories](https://avantree.com/ensemble/accessories)

# Introduzione al Prodotto

## Panoramica del Prodotto



## Tasti

No.	Tasti	Accendere/spegnere le cuffie
1	ON  OFF	Tenere premuto per regolare il volume
2	+ / -	Press or hold to adjust volume
3		Se le cuffie non riescono a connettersi automaticamente al trasmettitore, premere una volta per attivare la riconnessione
		Tenere premuto per 5 secondi per mettere le cuffie in modalità pairing
		Premere una volta per riprodurre/mettere in pausa l'audio (se utilizzate separatamente con telefono/tablet)
4	OFF  ON	Accendere/spegnere il trasmettitore
5		Tenere premuto per 5 secondi affinché il trasmettitore entri in modalità pairing

11

## Indicatori LED

No.	Indicatori	Stato
A	Blu lampeggiante	Acceso
	Blu fisso	Connesso
	Rosso e blu lampeggianti	Modalità pairing
	Rosso lampeggiante	Batteria scarica
	Rosso fisso	Ricarica
	Spento	Ricarica completata
B	Blu lampeggiante	Acceso
	Bliu fisso	Connesso
	Rosso e blu lampeggianti	Modalità Pairing
	Rosso fisso	Ricarica
	Verde fisso	Ricarica completa

## Uso con la TV

### Collegare il Trasmettitore alla TV

Il trasmettitore deve essere collegato a una fonte di alimentazione per funzionare. Collegalo a una presa tramite l'adattatore USB e il cavo di alimentazione forniti.

1

Per collegarle alle porte di uscita audio della TV, puoi scegliere una delle 3 diverse opzioni disponibili: adattatore ottico, aux 3,5 mm o RCA.

#### OPTION 1 - Uscita Ottica(raccomandata)

Inserire il cavo audio ottico incluso nella confezione alla porta DIGITAL AUDIO OUT(OPTICAL) del televisore, quindi inserire l'altra estremità nella porta ottica del trasmettitore.

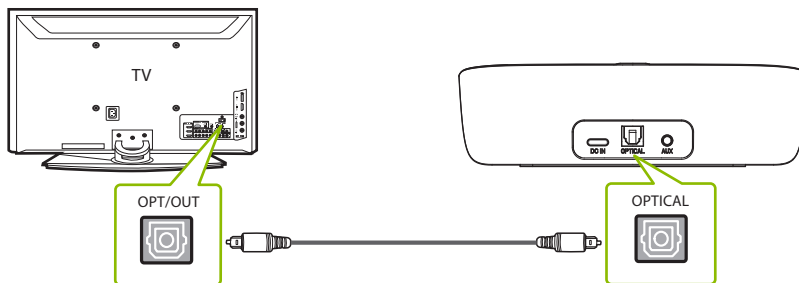

**NOTA:** la maggior parte dei televisori supporta solo un'uscita digitale. Quindi, se la porta HDMI ARC della TV è in uso, la porta ottica sarà disabilitata. Soluzioni alternative, scollegare l'HDMI ARC o collegare il trasmettitore tramite RCA/AUX.

**OPTION 2** - Uscita AUX 3.5mm

Collegare il cavo audio AUX da 3,5 mm incluso nella confezione alla porta di uscita AUX da 3,5 mm del televisore, quindi collegare l'altra estremità alla porta AUX da 3,5 mm del trasmettitore.

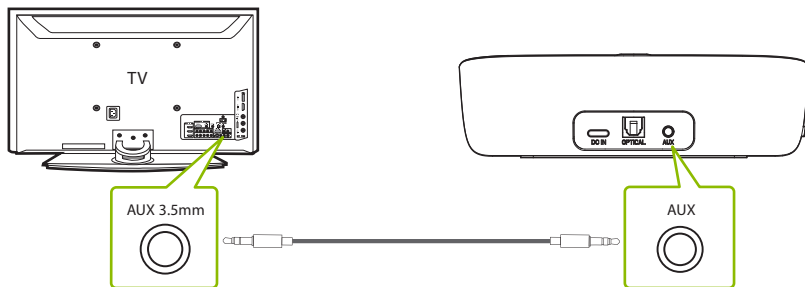
**OPTION 3** - Uscita RCA

Collegare l'adattatore RCA incluso nella confezione al cavo audio AUX da 3,5 mm. Collegare i connettori RCA rosso e bianco alle porte "AUDIO OUT" del televisore, quindi collegare l'altra estremità alla porta AUX da 3,5 mm del trasmettitore.

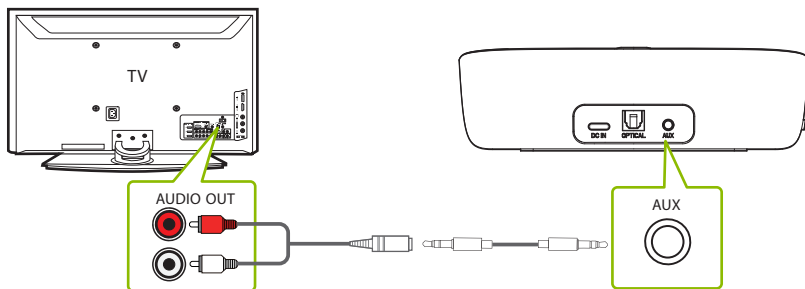

## Collegare le Cuffie al Trasmettitore

### PASSO 1

Sulle cuffie, fai scorrere l'interruttore ON/OFF su ON, l'indicatore LED dovrebbe lampeggiare in blu. Sulle cuffie, fai scorrere l'interruttore ON/OFF su ON, l'indicatore LED dovrebbe lampeggiare in blu.

### PASSO 2

Il trasmettitore è impostato per impostazione predefinita sulla posizione ON, in caso contrario, far scorrere l'interruttore ON/OFF del trasmettitore su ON, l'indicatore LED dovrebbe lampeggiare in blu.

### PASSO 3

Mantienili vicini e si collegheranno entro 3-5 secondi, sia l'indicatore sulle cuffie che l'indicatore del trasmettitore diventano di colore blu fisso.

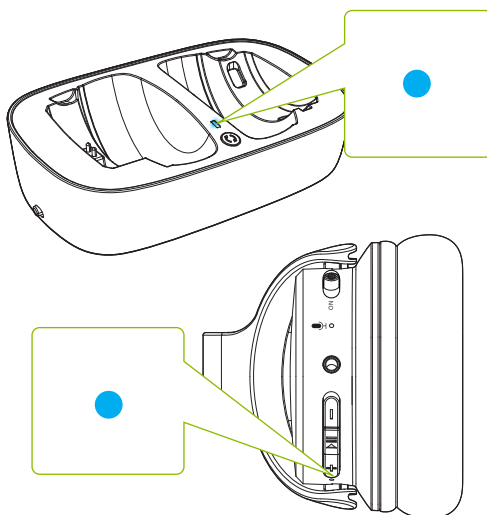



## Impostazione della TV (solo per connessione Ottica)

Se ti sei connesso alla TV tramite l'Uscita Ottica o la porta "OPT OUT", dovrai configurare le impostazioni della TV prima di sentire l'audio.

### PASSO 1

Utilizzando il telecomando della TV, premi il pulsante IMPOSTAZIONI e vai alla scheda AUDIO all'interno del menu delle impostazioni. (Potrebbero esserci differenze nei nomi delle impostazioni a seconda della marca del televisore).

### PASSO 2

Andare su USCITA AUDIO e selezionare "USCITA OTTICA / USCITA DIGITAL". Molti televisori lo fanno automaticamente; saltare questo passaggio se necessario.

### PASSO 3

Impostare il formato dell'Uscita Audio su "PCM / STEREO" ON o "DOLBY" OFF.

Se hai difficoltà a trovare queste impostazioni, puoi scansionare il codice QR correlato al marchio della tua TV O visitare

[avantree.com/ensemble/tv-audio-settings](http://avantree.com/ensemble/tv-audio-settings) per una guida più dettagliata.



LG



SONY



SAMSUNG

*NOTA 1: Alcune smart TV si ripristinano automaticamente dopo l'aggiornamento del sistema, controllare che il formato di uscita/ingresso audio sia impostato come PCM anziché AUTO o Dolby.*

*NOTA 2: Durante la visione di Netflix e Amazon Prime, potrebbe essere necessario avviare il film prima di passare a PCM.*

## Funzionalità Avanzate

### Aggiungere un Secondo Paio di Cuffie

Puoi aggiungere un secondo paio di cuffie Ensemble (AS50) alla tua configurazione mantenendo la bassa latenza.

1

#### PASSO 1

Assicurati che le cuffie e il trasmettitore Ensemble originali siano collegati.

#### PASSO 2

Sul trasmettitore, tieni premuto il pulsante  finché l'indicatore LED non lampeggia in rosso e blu.

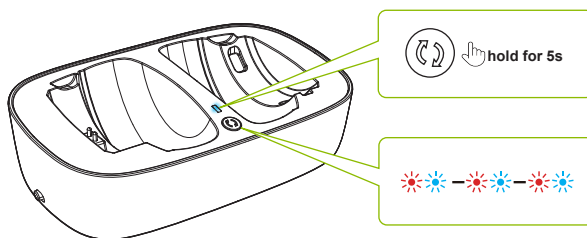

#### PASSO 3

Accendi il secondo paio di cuffie AS50, quindi tieni premuto il pulsante  finché l'indicatore LED non lampeggia in rosso e blu.

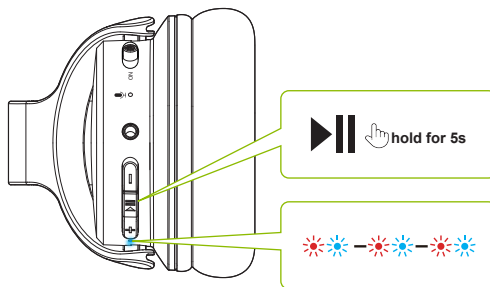

## PASSO 4

Una volta collegati, gli indicatori LED delle cuffie e del trasmettitore diventeranno blu fissi.

**Per l'uso successivo**, accendere prima il paio di cuffie Ensemble originali. Una volta collegate al trasmettitore, puoi accendere il tuo secondo paio di cuffie AS50 e attendere alcuni secondi. Se non riescono a riconnettersi, premere il pulsante ►|| una volta per attivare la riconnessione.

Per acquistare le cuffie AS50, scansiona il codice QR



## Usare le Cuffie con Telefono/Tablet

### PASSO 1

SPEGNERE il trasmettitore.

### PASSO 2

Accendi le cuffie, tieni premuto il pulsante ►|| finché l'indicatore LED non lampeggia in rosso e blu.

### PASSO 3

Attiva il Bluetooth della tua sorgente audio e seleziona "Avantree AS50" dal menu Bluetooth.

## Ricaricare le Cuffie

Posizionare le cuffie sul dock di ricarica per ricaricarle. Il LED del dock di ricarica diventerà rosso durante la ricarica e verde una volta completata la ricarica.

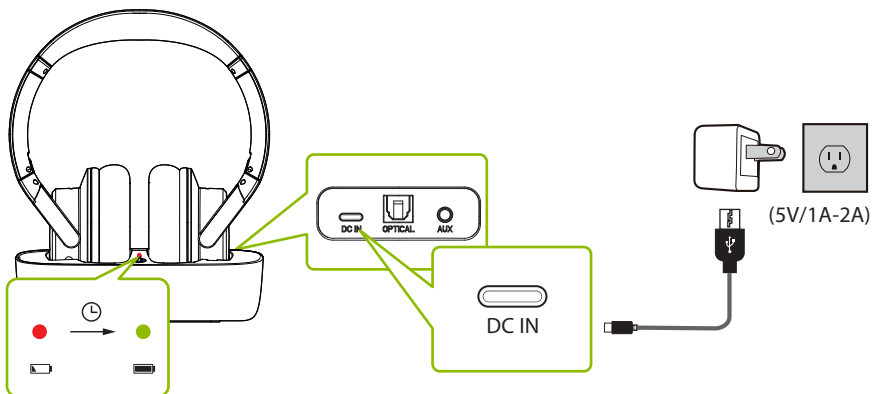

Puoi anche caricare le cuffie attraverso le porte di alimentazione utilizzando un cavo di ricarica. Una luce rossa fissa indica che la ricarica è in corso; una volta che la luce si spegne, le cuffie saranno completamente cariche. Di solito sono necessarie 3 ore per una ricarica completa.

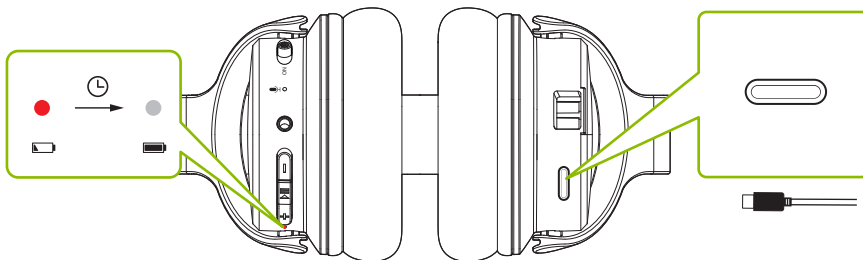

## Specifiche

### Trasmettitore

Versione Bluetooth	V5.0
Frequenza di risposta	20Hz - 20KHz
Raggio di operatività	Fino a 100ft / 30m
Profili Bluetooth	HFP v1.7, AVRCP v1.5, A2DP v1.3
Codec audio supportati	aptX-LL, aptX, FastStream, SBC

### Cuffie

Versione Bluetooth	V5.0
Frequenza di risposta	20Hz-20KHz
Profili Bluetooth	HSP v1.2, HFP v1.6, AVRCP v1.0, A2DP v1.0
Codec audio supportati	FastStream, SBC
Durata batteria	Fino a 35 ore
Impedenza	32Ω
Peso netto	234g
Misura interna della cuffia	55±1.5 * 43±1.5 * 15±1.5mm

## FAQ

Di seguito sono riportate alcune delle domande più comuni che le persone hanno durante l'installazione.

### **Ho un televisore Samsung/LG. Perché le mie cuffie non riescono a riconnettersi al trasmettitore?**

Le smart TV Samsung/LG tendono ad accoppiarsi con qualsiasi dispositivo Bluetooth che riescano a trovare, il che impedisce alle cuffie Avantree di riconnettersi al trasmettitore. Prova a seguire i passaggi seguenti per risolvere questo problema:

**RIFIUTARE il Dispositivo** - Se sulla TV viene visualizzato un popup che chiede di consentire o rifiutare/bloccare la connessione del dispositivo alla TV, è NECESSARIO RIFIUTARE/BLOCCARE la connessione del dispositivo.

**RIMUOVERE il Dispositivo** - Se il tuo dispositivo è già associato alla TV, dovrai rimuovere il dispositivo nelle impostazioni della TV: IMPOSTAZIONI > GENERALI > GESTIONE DISPOSITIVI ESTERNI > GESTIONE CONNESSIONE DISPOSITIVO > ELENCO DISPOSITIVI > MODIFICA > Seleziona tutti i dispositivi Avantree > ELIMINA.

Tieni presente che il percorso può variare in base alla marca/modello della TV.

**SPEGNERE la TV** - Spegnerne fisicamente il televisore o staccare la spina (il telecomando NON spegne il televisore; lo mette in modalità standby che consente comunque al televisore di connettersi ai dispositivi).

### **Posso ascoltare l'audio tramite gli altoparlanti delle TV e le cuffie wireless contemporaneamente?**

Se desideri ascoltare l'audio contemporaneamente sia sugli altoparlanti della TV che sulle cuffie, questa funzione DIPENDE dal fatto che la TV sia in grado di supportare l'uscita dell'audio su due sorgenti contemporaneamente. NON è correlato al trasmettitore. Il trasmettitore riceve l'audio dall'uscita della TV e lo trasmette alle cuffie o agli altoparlanti wireless. Puoi provare diversi modi per verificare se la tua TV supporta questa funzione. Per maggiori dettagli, fare riferimento a [avantree.com/ensemble/sound](https://avantree.com/ensemble/sound).

### **Perché non sento il suono quando guardo Netflix/Amazon Prime? Le cuffie non si collegano al trasmettitore?**

.....

Per risposte a domande come queste e per un elenco completo di domande frequenti, puoi visitare [avantree.com/support/ensemble](https://avantree.com/support/ensemble) oppure puoi contattarci direttamente per ulteriore assistenza.

## Contattaci

**Ticket Supporto**[avantree.com/submit-a-ticket](https://avantree.com/submit-a-ticket)**Email Supporto**[support@avantree.com](mailto:support@avantree.com)**USA / CA**

+1800 232 2078 (9am-6pm PST, Mon-Fri)

**UK**

+44 20 8068 2023 (9am-6pm, GMT, Mon-Sat)

**DE**

+49 32221097297 (11am-9pm, CET, Mon-Sat)

**FR**

+ 33 176340312 (11am-9pm, CET, Mon-Sat)

**IT**

+39 06 9480 3330 (9am-6pm, CET, Mon-Sat)

**ES**

+ 34 931786261 (9am-6pm, CET, Mon-Sat)

**AU**

+ 61 2 8310 9897 (11am-7pm, AEST, Mon-Fri)

**FAQ**[avantree.com/support/ensemble](https://avantree.com/support/ensemble)**Videoguida**[avantree.com/ensemble/video](https://avantree.com/ensemble/video)**Registrazione del prodotto**[avantree.com/product-registration](https://avantree.com/product-registration)

## Videoguía

Prefieres ver un video tutorial? Escanee el código QR a continuación o visite [avantree.com/ensemble/video](https://avantree.com/ensemble/video) para obtener una guía detallada.



ES

## Reservar una Cita



También puede reservar una cita de instalación 1 a 1 con uno de nuestros agentes de soporte en [avantree.com/book-a-call](https://avantree.com/book-a-call)



# Índice de contenido

<b>Contenidos del Paquete</b> .....	64
<b>Introducción del Producto</b> .....	65
Descripción del Producto .....	65
Tecls .....	66
Indicadores LED .....	66
<b>Usar con Televisor</b> .....	67
Conectar el Transmisor al Televisor .....	67
Opción 1 - Salida Óptica(recomendado) .....	67
Opción 2 - Salida AUX 3.5mm .....	68
Opción 3 - Salida RCA .....	68
Conectar los Auriculares al Transmisor .....	69
Configuración de TV (solo para conexión Óptica) .....	70
<b>Características avanzadas</b> .....	71
Agregar un Segundo Par de Auriculares .....	71
Uso de Auriculares con Teléfono/Tableta .....	72
<b>Recargar los auriculares</b> .....	73
<b>Especificaciones</b> .....	74
<b>FAQ</b> .....	75
<b>Contactos</b> .....	76

# Contenidos del Paquete

ES

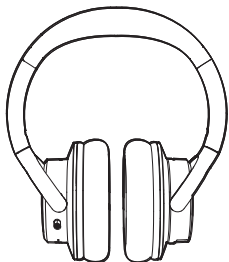

Auriculares

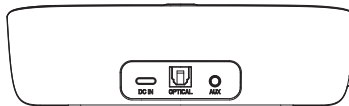

Trasmettitore/Base di Ricarica

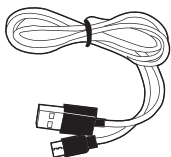

Cable de Alimentación del Transmisor

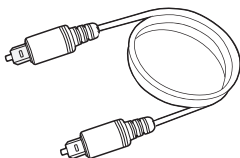

Adaptador AUX a RCA de 3,5 mm

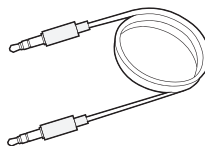

Cable de Audio AUX de 3,5 mm

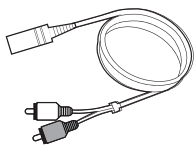

Adaptador AUX a RCA de 3,5 mm

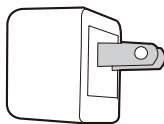

Cargador usb

Para ver y comprar accesorios de Ensamble, visite el sitio [avantree.com/ensemble/accessories](http://avantree.com/ensemble/accessories)



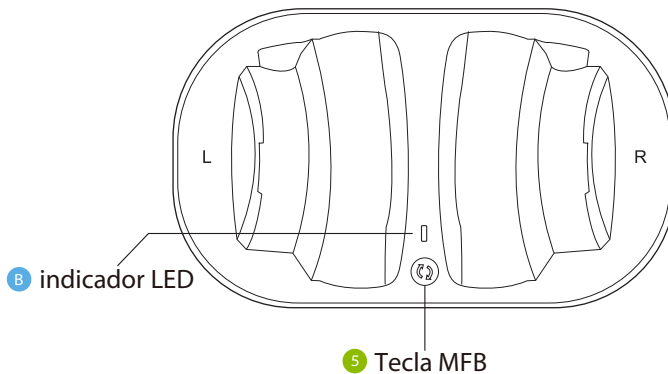
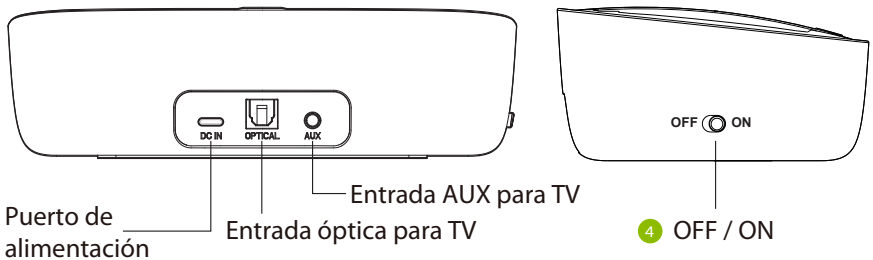
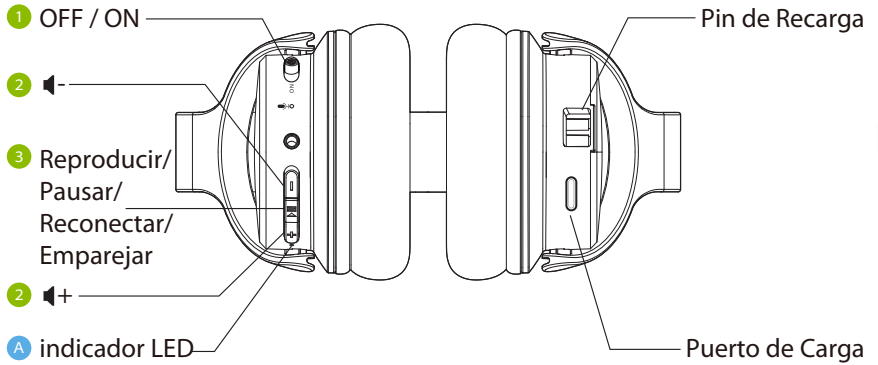

# Introducción del Producto

## Descripción del Producto



ES

## Tecls

No.	Tecls	Función
1	ON  OFF	Encender/apagar los auriculares
2	+ / -	Mantenga presionado para ajustar el volumen
3		Si los auriculares no se conectan automáticamente al transmisor, presione una vez para activar la reconexión
		Mantenga presionado durante 5 segundos para poner los auriculares en modo de emparejamiento
		Presione una vez para reproducir/pausar audio (cuando se usa por separado con teléfono/tableta)
4	OFF  ON	Encender/apagar el transmisor
5		Mantenga presionado durante 5 segundos para que el transmisor ingrese al modo de emparejamiento

## Indicadores LED

No.	Indicadores	Estado
A	Azul intermitente	Encendido
	Azul fijo	Conectado
	Parpadeo rojo y azul	Modo de emparejamiento
	Rojo intermitente	Batería baja
	Rojo fijo	Carga
	Apagado	Carga completada
B	Azul intermitente	Encendido
	Azul fijo	Conectado
	Parpadeo rojo y azul	Modo de emparejamiento
	Rojo fijo	Carga
	Verde fijo	Carga completada

## Usar con Televisor

### Conectar el Transmisor al Televisor

El transmisor debe estar conectado a una fuente de alimentación para funcionar. Conéctelo a una toma de corriente con el adaptador USB y el cable de alimentación proporcionados.

Para conectarlos a los puertos de salida de audio de tu TV, puedes elegir una de las 3 opciones diferentes disponibles: adaptador óptico, aux 3.5mm o RCA.

#### OPTION 1 - Salida Óptica(recomendado)

Enchufe el cable de audio óptico incluido en el puerto SALIDA DE AUDIO DIGITAL (OPTICAL) en el televisor, luego enchufe el otro extremo en el puerto óptico en el transmisor.

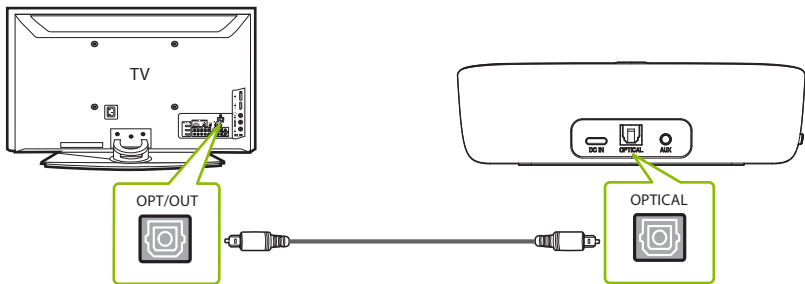

*NOTA: La mayoría de los televisores solo admiten una salida digital. Entonces, si el puerto HDMI ARC del televisor está en uso, el puerto óptico se desactivará. Soluciones alternativas, desconecte el HDMI ARC o conecte el transmisor a través de RCA/AUX.*

**OPTION 2** - Salida AUX 3.5mm

Conecte el cable de audio AUX de 3,5 mm incluido en el paquete al puerto de salida AUX de 3,5 mm en el televisor, luego conecte el otro extremo al puerto AUX de 3,5 mm en el transmisor.

ES

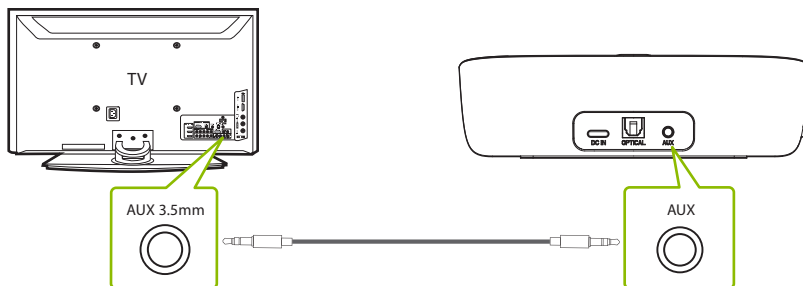

**OPTION 3** - Salida RCA

Conecte el adaptador RCA incluido al cable de audio AUX de 3,5 mm. Enchufe los enchufes RCA rojo y blanco en los puertos "AUDIO OUT" de su televisor, luego enchufe el otro extremo en el puerto AUX de 3,5 mm de su transmisor.

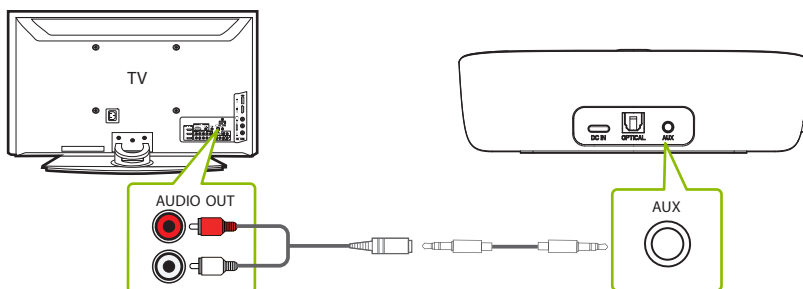

## Conectar los Auriculares al Transmisor

### PASO 1

En los auriculares, deslice el interruptor ON/OFF a ON, el indicador LED debe parpadear en azul.

### PASO 2

El transmisor está predeterminado en la posición ON, si no, deslice el interruptor ON/OFF del transmisor a ON, el indicador LED debe parpadear en azul.

### PASO 3

Manténgalos cerca y se conectarán en 3 a 5 segundos, tanto el indicador de los auriculares como el indicador del transmisor se volverán azules fijos.

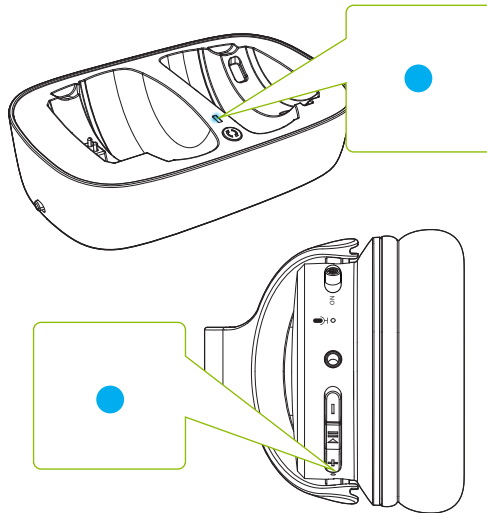

## Configuración de TV (solo para conexión Óptica)

Si se conectó al televisor a través de la Salida Óptica o el puerto "OPT OUT", deberá configurar los ajustes del televisor antes de escuchar el audio.

### PASO 1

Con el control remoto de su televisor, presione el botón CONFIGURACIÓN y navegue hasta la pestaña SONIDO dentro del menú de configuración. (Puede haber diferencias en los nombres de los ajustes según la marca de su televisor).

### PASO 2

Vaya a SALIDA DE AUDIO y seleccione "SALIDA ÓPTICA / SALIDA DIGITAL". Muchos televisores hacen esto automáticamente; omita este paso si es necesario.

### PASO 3

Establezca el formato de salida de audio en "PCM / STEREO" ON o "DOLBY" OFF.

Si tiene problemas para encontrar esta configuración, puede escanear el código QR relacionado con la marca de su televisor O visitar [avantree.com/ensemble/tv-audio-settings](http://avantree.com/ensemble/tv-audio-settings) para obtener una guía más detallada.



LG



SONY



SAMSUNG

*NOTA 1: Algunos televisores inteligentes se reinician automáticamente después de la actualización del sistema, verifique que el formato de entrada/salida de audio esté configurado como PCM en lugar de AUTO o Dolby.*

*NOTA 2: Cuando vea Netflix y Amazon Prime, es posible que deba iniciar la película antes de cambiar a PCM.*



## Agregar un Segundo Par de Auriculares

Puede agregar un segundo par de auriculares Ensemble (AS50) a su configuración mientras mantiene una latencia baja.

### PASO 1

Asegúrese de que sus auriculares y transmisor Ensemble originales estén conectados.

### PASO 2

En el transmisor, mantenga presionado el botón  hasta que el indicador LED parpadee en rojo y azul.

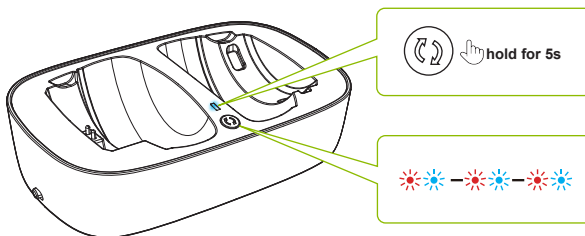

### PASO 3

Encienda el segundo par de auriculares AS50, luego presione y mantenga presionado el botón  hasta que el indicador LED parpadee en rojo y azul.

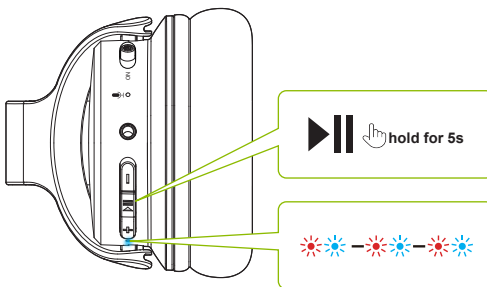

ES

## PASO 4

Una vez conectado, los indicadores LED de los auriculares y el transmisor se volverán azules fijos.

**Para uso posterior**, encienda primero el par original de auriculares Ensemble. Una vez conectado al transmisor, puede encender su segundo par de auriculares AS50 y esperar unos segundos. Si no puedan volver a conectarse, presione el botón ►|| una vez para activar la reconexión.

Para comprar auriculares AS50, escanear el código QR



## Uso de Auriculares con Teléfono/Tableta

### PASO 1

APAGUE el transmisor.

### PASO 2

Encienda los auriculares, mantenga presionado el botón ►|| hasta que el indicador LED parpadee en rojo y azul.

### PASO 3

Active el Bluetooth de su fuente de audio y seleccione "Avantree AS50" en el menú de Bluetooth.

## Recargar los auriculares

Coloque los auriculares en la base de carga para cargarlos. El LED de la base de carga se volverá rojo durante la carga y verde una vez que se complete la carga.

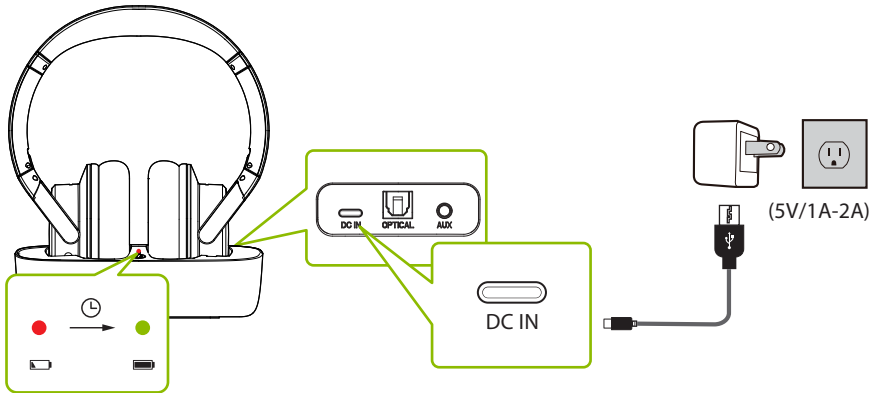

También puede cargar los auriculares a través de los puertos de alimentación con un cable de carga. Una luz roja fija indica que la carga está en curso; una vez que la luz se apague, los auriculares estarán completamente cargados. Por lo general, toma 3 horas para una carga completa.

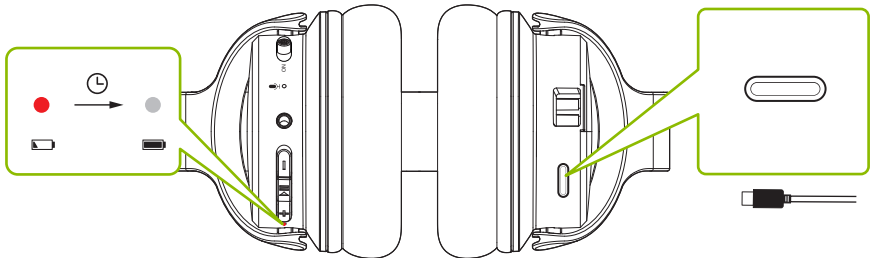

## Especificaciones

### Transmisor

Versión Bluetooth	V5.0
Tasa de respuesta	20Hz - 20KHz
Radio de conexión	Hasta a 100ft / 30m
Perfiles de Bluetooth	HFP v1.7, AVRCP v1.5, A2DP v1.3
Códecs de audio compatibles	aptX-LL, aptX, FastStream, SBC

### Auriculares

Versión Bluetooth	V5.0
Tasa de respuesta	20Hz-20KHz
Perfiles de Bluetooth	HSP v1.2, HFP v1.6, AVRCP v1.0, A2DP v1.0
Códecs de audio compatibles	FastStream, SBC
Duración de la batería	Hasta a 35 horas
Impedancia	32Ω
Peso	234g
Tamaño interior de la tapa	55±1.5 * 43±1.5 * 15±1.5mm

## FAQ

A continuación se presentan algunas de las preguntas más comunes que la gente tiene al instalar.

### **Tengo un televisor Samsung/LG. Por qué mis auriculares no pueden volver a conectarse al transmisor?**

Los televisores inteligentes Samsung/LG tienden a emparejarse con cualquier dispositivo Bluetooth que puedan encontrar, lo que evita que los auriculares Avantree se vuelvan a conectar al transmisor. Intente seguir los pasos a continuación para solucionar este problema:

**RECHAZAR el dispositivo** - Si aparece una ventana emergente en el televisor que solicita permitir o rechazar/bloquear la conexión del dispositivo al televisor, DEBE RECHAZAR/BLOQUEAR la conexión del dispositivo.

**ELIMINAR el dispositivo** - Si su dispositivo ya está emparejado con el televisor, deberá eliminar el dispositivo en la configuración del televisor: CONFIGURACIÓN > GENERAL > ADMINISTRAR DISPOSITIVOS EXTERNOS > ADMINISTRAR CONEXIÓN DEL DISPOSITIVO > LISTA DE DISPOSITIVOS > EDITAR > Seleccionar todos los dispositivos Avantree > ELIMINAR.

Tenga en cuenta que las instrucciones pueden diferir según la marca o el modelo de su televisor..

**APAGAR la televisión** - Apague físicamente el televisor o desenchúfelo (el control remoto NO apaga el televisor; lo pone en modo de espera, lo que aún permite que el televisor se conecte a sus dispositivos).

### **Puedo escuchar audio a través de los parlantes del televisor y los auriculares inalámbricos al mismo tiempo?**

Si desea escuchar audio en los parlantes del televisor y en los auriculares al mismo tiempo, esta función DEPENDE de si su televisor admite la salida de audio a dos fuentes simultáneamente. NO está relacionado con el transmisor. El transmisor recibe audio de la salida del televisor y lo transmite a sus auriculares o altavoces inalámbricos. Puede probar diferentes formas de verificar si su televisor es compatible con esta función. Para obtener más detalles, consulte [avantree.com/ensemble/sound](http://avantree.com/ensemble/sound)

### **Por qué no puedo escuchar el sonido cuando veo Netflix/Amazon Prime?**

#### **Los auriculares no se conectan al transmisor?**

.....

Para obtener respuestas a preguntas como estas y para obtener una lista completa de las preguntas más frecuentes, puede visitar [avantree.com/support/ensemble](http://avantree.com/support/ensemble) o puede comunicarse con nosotros directamente para obtener más ayuda.

## Contáctenos

**Tickets de Soporte**[avantree.com/submit-a-ticket](https://avantree.com/submit-a-ticket)**Mail de Soporte**[support@avantree.com](mailto:support@avantree.com)**USA / CA**

+1800 232 2078 (9am-6pm PST, Mon-Fri )

**UK**

+44 20 8068 2023 (9am-6pm, GMT, Mon-Sat)

**DE**

+49 32221097297 (11am-9pm, CET, Mon-Sat )

**FR**

+ 33 176340312 (11am-9pm, CET, Mon-Sat )

**IT**

+39 06 9480 3330 (9am-6pm, CET, Mon-Sat )

**ES**

+ 34 931786261 (9am-6pm, CET, Mon-Sat )

**AU**

+ 61 2 8310 9897 (11am-7pm, AEST, Mon-Fri)

**FAQ**[avantree.com/support/ensemble](https://avantree.com/support/ensemble)**Videoguía**[avantree.com/ensemble/video](https://avantree.com/ensemble/video)**Registración del Producto**[avantree.com/product-registration](https://avantree.com/product-registration)

## 動画ガイド

チュートリアル動画をご覧になりたい場合は、以下のQRコードをスキャンするか、[avantree.com/ensemble/video](https://avantree.com/ensemble/video) でステップバイステップガイドをご覧ください。



d1

## 1対1のセットアップサポートの予約



当社のサポートエージェントによる1対1のセットアップサポートの予約は、[avantree.com/book-a-call](https://avantree.com/book-a-call) で行うことができます。

# 目次

箱の内容	79
製品概要	80
各部名称	80
ボタン	81
LEDインジケータ	81
<b>JP</b> テレビ視聴に使用する	82
送信機をテレビに接続する	82
オプション1 - 光デジタル端子 (推奨)	82
オプション2 - 3.5mm AUX端子	83
オプション3 - RCA端子	83
ヘッドホンを送信機に接続する	84
テレビを設定する (光デジタル接続のみ)	85
アドバンスド機能	86
2台目のヘッドホンを追加する	86
スマホ・タブレットでヘッドホンを使う	87
ヘッドホンの充電	88
製品仕様	89
FAQ よくあるご質問 (FAQ)	90
お問い合わせ	91



## 箱の内容

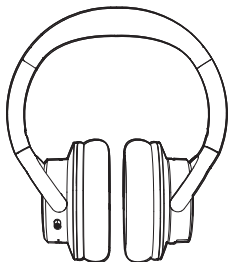

ヘッドホン

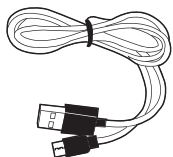
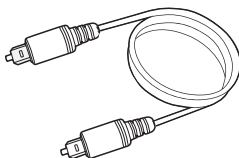
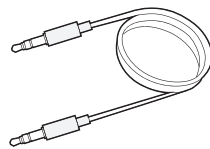
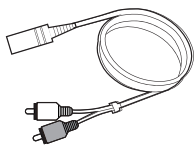
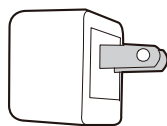

送信機 / 充電ドック

送信機用電源  
ケーブル光デジタル  
音声ケーブル3.5mm AUX  
オーディオケーブル3.5mm AUX to RCA  
変換アダプター

USB充電器



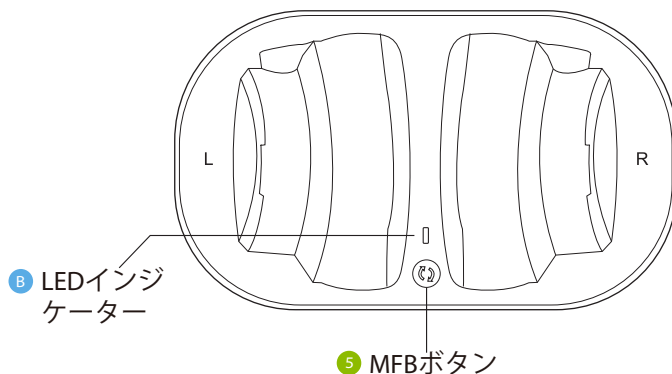
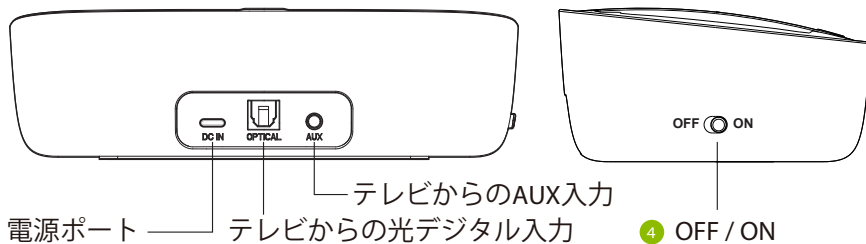
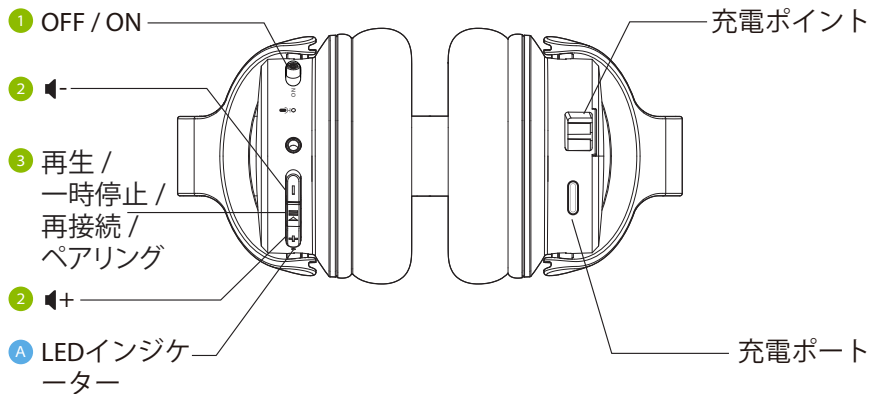

Ensembleのアクセサリーの閲覧・購入は、  
[avantree.com/ensemble/accessories](https://avantree.com/ensemble/accessories)をご覧ください。

# 製品概要

## 各部名称



## ボタン

No.	ボタン	操作方法
①	ON  OFF	「ON / OFF」の位置に合わせて、ヘッドホンがオン/オフになります
②	+ / -	1回押すか長押しして音量を調節します
③		ヘッドホンが送信機との自動接続に失敗した場合、1回押しして再接続を有効にします
		5秒間長押しすると、ヘッドホンがペアリングモードになります
		1回押すと、音声を再生/一時停止します（スマホ/タブレット単体で使用する場合）
④	OFF  ON	「ON / OFF」の位置に合わせて、送信機がオン/オフになります
⑤		5秒間長押しすると、送信機がペアリングモードになります

## LEDインジケータ

No.	インジケータ	ステータス
A	青色点滅	電源オン
	青色点灯	接続済み
	赤・青の点滅	ペアリングモード
	赤色点滅	バッテリー残量低下
	赤色点灯	充電中
	消灯	充電完了
B	青色点滅	電源オン
	青色点灯	接続済み
	赤・青の点滅	ペアリングモード
	赤色点灯	充電中
	緑色点灯	充電完了

## テレビ視聴に使用する

### 送信機をテレビに接続する

送信機を機能させるには、電源に接続する必要があります。付属のUSBアダプターと電源ケーブルを使って、近くのコンセントに接続します。

テレビの音声出力端子に接続する場合、光デジタル、3.5mm AUX、RCAアダプターの3種類から1つを選んで接続することができます。

JP

#### オプション1 - 光デジタル端子 (推奨)

付属の光デジタル音声ケーブルをテレビの「光デジタル出力(OPTICAL)」端子に差し込み、もう一方の端を送信機的光デジタル出力端子に差し込みます。

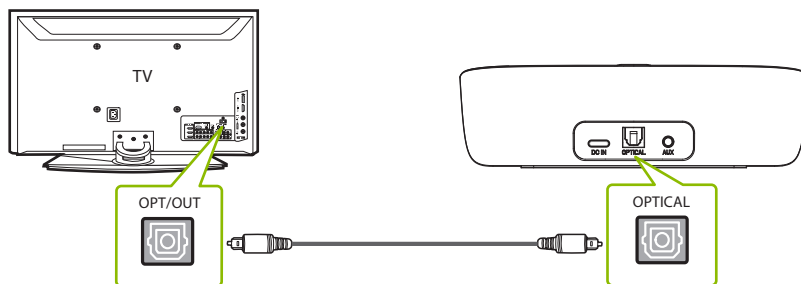

注意: ほとんどのテレビは、1つのデジタル出力にしか対応していません。そのため、テレビのHDMI ARC端子が使用されている場合は、光デジタル端子が無効になります。その場合は、HDMI ARCを外すか、RCA/AUXで送信機を接続してください。

### オプション2 - 3.5mm AUX端子

付属の3.5mm AUXオーディオケーブルをテレビの3.5mm AUX出力端子に差し込み、もう一方の端を送信機の3.5mm AUX端子に差し込みます。

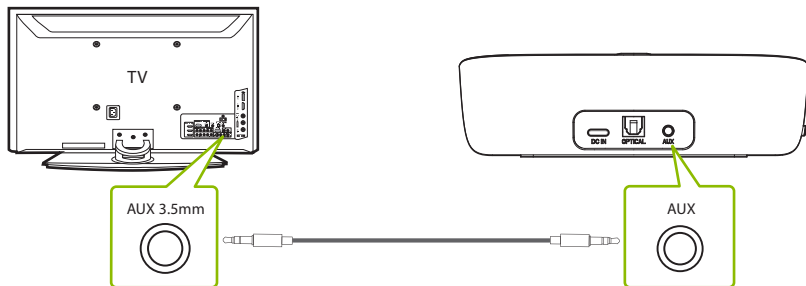

### オプション3 - RCA端子

付属のRCAアダプターをAUX3.5mmオーディオケーブルに接続します。赤と白のRCAコネクタをテレビの「AUDIO OUT」端子に差し込み、もう一方の端を送信機の3.5mm AUX端子に差し込みます。

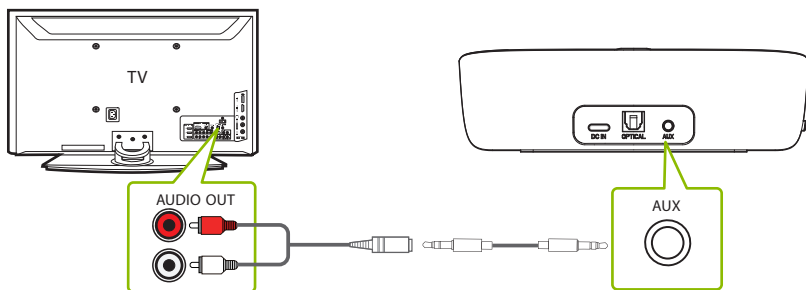

## ヘッドホンを送信機に接続する

### ステップ 1

ヘッドホンのON/OFFスイッチをONにスライドさせると、LEDインジケーターが青く点滅します。

### ステップ 2

送信機はデフォルトでONになっていますが、ONになっていない場合は、送信機のON/OFFスイッチをONにスライドさせると、LEDインジケーターが青色に点滅します。

### ステップ 3

ヘッドホンと送信機を近づけると、3～5秒以内に接続され、ヘッドホンと送信機のインジケーターが青色に点灯します。

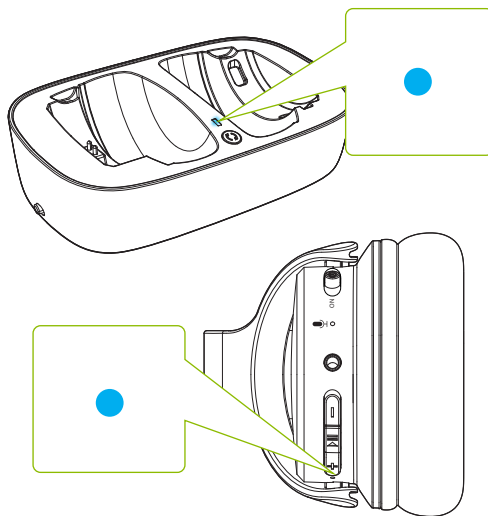

## テレビを設定する（光デジタル接続のみ）

「光デジタル出力」端子でテレビに接続した場合、音声を受信する前にテレビの設定が必要です。

### ステップ 1

テレビのリモコンで「設定」ボタンを押し、設定メニュー内の「音声」タブに移動します（テレビのブランドによって、設定名称が異なる場合があります）。

### ステップ 2

「音声出力」に進み、「光デジタル出力 / デジタル出力」を選択します。多くのテレビでは自動的に行われますので、必要に応じてこの手順をスキップしてください。

### ステップ 3

音声出力形式を「PCM / ステレオ」ONまたは「ドルビー」OFFに設定します。

これらの設定が見つからない場合は、以下のテレビのブランドのQRコードをスキャンするか、[avantree.com/ensemble/tv-audio-settings](https://avantree.com/ensemble/tv-audio-settings) でより詳しいガイドをご覧ください。



LG



SONY



SAMSUNG

注意1: 一部のスマートテレビでは、システムアップグレード後に自動でリセットされます。音声出力/入力フォーマットがAUTOやドルビーではなく、PCMであることを確認してください。

注意2: NetflixやAmazonプライムの視聴中は、PCMに変更する前に、まず映画を開始する必要がある場合があります。

## アドバンスド機能

### 2台目のヘッドホンを追加する

低レイテンシーを維持したまま、2台目のEnsembleヘッドホン (AS50) を設定に追加することが可能です。

#### ステップ 1

1台目のEnsembleヘッドホンと送信機が接続されていることを確認します。

#### ステップ 2

送信機で、LEDインジケーターが赤と青に点滅するまで  ボタンを長押しします。

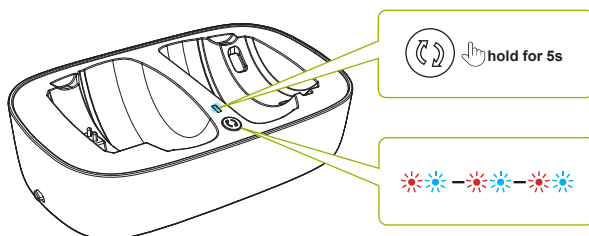

#### ステップ 3

2台目のAS50ヘッドホンの電源を入れ、LEDインジケーターが赤と青に点滅するまで  ボタンを長押しします。

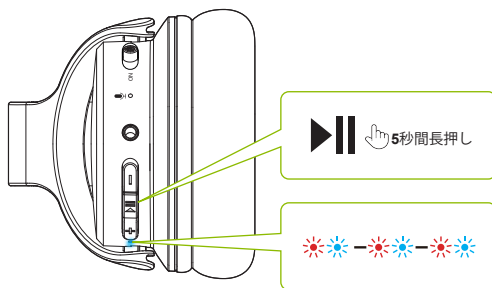



#### ステップ 4

接続すると、ヘッドホンと送信機のLEDインジケーターが青く点灯します。

**2回目以降に使用する場合は、**まず1台目のEnsembleヘッドホンの電源をONにします。1台目のヘッドホンが送信機に接続されたら、2台目のAS50ヘッドホンの電源を入れ、数秒間待ちます。再接続に失敗した場合は、▶|| ボタンを1回押して再接続を有効にします。

AS50ヘッドホンのご購入は、QRコードを読み取ってください。



### スマホ・タブレットでヘッドホンを使う

#### ステップ 1

送信機の電源をOFFにするか、コンセントを抜きます。

#### ステップ 2

ヘッドホンの電源を入れ、LEDインジケーターが赤と青に点滅するまで▶|| ボタンを長押しします。

#### ステップ 3

音声ソースのBluetoothをONにして、Bluetoothメニューから「Avantree AS50」を選択します。

## ヘッドホンの充電

充電するには、ヘッドホンを充電ドックにセットします。充電ドックのLEDは、充電中は赤色に、充電が完了すると緑色に点灯します。

JP

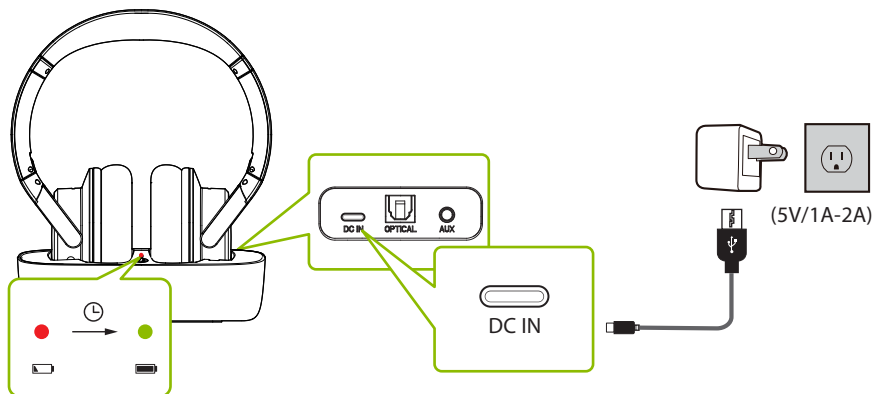

また、充電ケーブルを使用して、ヘッドホンの電源ポートから充電することも可能です。赤色の点灯は充電中であることを示し、消灯するとヘッドホンのバッテリーが完全に充電されたことを示します。通常、フル充電には3時間かかります。

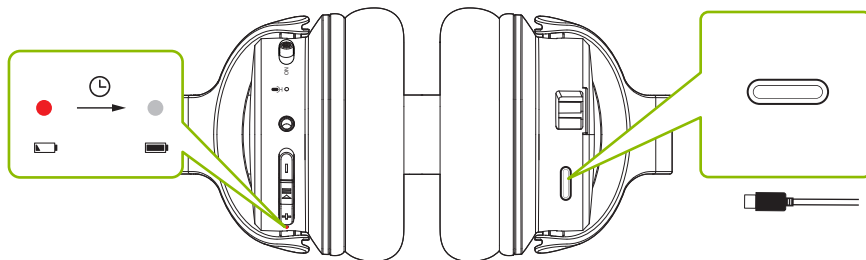

## 製品仕様

### 送信機

Bluetoothのバージョン	V5.0
周波数特性	20Hz - 20KHz
動作範囲	最大100ft / 30m
Bluetoothのプロファイル	HFP v1.7, AVRCP v1.5, A2DP v1.3
対応音声コーデック	aptX-LL, aptX, FastStream, SBC

### ヘッドホン

Bluetoothのバージョン	V5.0
周波数特性 (Hz)	20Hz-20KHz
Bluetoothのプロファイル	HSP v1.2, HFP v1.6, AVRCP v1.0, A2DP v1.0
対応音声コーデック	FastStream, SBC
バッテリー駆動時間	最大35時間
インピーダンス	32Ω
正味重量	234g
イヤークッション内径サイズ	55±1.5 * 43±1.5 * 15±1.5mm

## FAQ よくあるご質問 (FAQ)

セットアップ時によくある質問を以下にご紹介します。

**サムスン/LGのテレビを持っています。ヘッドホンが送信機との再接続に失敗するのはなぜですか？**

サムスン/LGのスマートテレビは、Bluetoothデバイスを見つけるとペアリングする傾向があり、Avantreeヘッドホンが送信機に再接続するのをブロックしてしまいます。これを解決するには、以下の手順を試してみてください。

JP

**デバイスを拒否する** - テレビにポップアップが表示され、デバイスの接続を許可または拒否/ブロックするよう求められた場合、デバイスの接続を拒否/ブロックする必要があります。

**デバイスを削除する** - デバイスがすでにテレビとペアリングされている場合、テレビの設定でデバイスを削除する必要があります: 設定 > 一般 > 外部デバイスマネージャー > デバイス接続 > デバイスリスト > 編集 > すべての

**Avantreeデバイスを選択 > 削除**

テレビのブランドやモデルによって、ルーティングが異なる場合がありますので、ご注意ください。

**テレビの電源を切る** - テレビの電源を**OFF**にするか、コンセントを抜きます (リモコンはテレビの電源を切らず、スタンバイモードにし、テレビがデバイスに接続できるようにします)。

**テレビのスピーカーとワイヤレスヘッドホンから同時に音を出せますか？**

テレビのスピーカーとヘッドホンの両方から同時に音を出したい場合は、テレビが2つのソースに同時に音を出すことに対応しているかどうかで決まります。送信機とは関係ありません。送信機は、テレビの出力から音を受信し、ワイヤレスヘッドホンやスピーカーにストリーミングします。様々な方法を試してみて、問題ないかどうか確認してみてください。詳しくは、[avantree.com/ensemble/sound](https://avantree.com/ensemble/sound)を参照してください。

**Netflix/Amazonプライムの視聴中に音が出ないのはなぜですか？**

ヘッドホンが送信機に接続できません。

.....

このような質問への回答やFAQの全一覧については、

[avantree.com/support/ensemble](https://avantree.com/support/ensemble)をご覧ください。どうか、当社に直接お問い合わせいただくと、さらに詳しい情報を得ることができます。

## お問い合わせ



サポートチケット

[avantree.com/submit-a-ticket](https://avantree.com/submit-a-ticket)

サポートメール

[support@avantree.com](mailto:support@avantree.com)

USA / CA

+1800 232 2078 (9am-6pm PST, Mon-Fri)

UK

+44 20 8068 2023 (9am-6pm, GMT, Mon-Sat)

DE

+49 32221097297 (11am-9pm, CET, Mon-Sat)

FR

+ 33 176340312 (11am-9pm, CET, Mon-Sat)

IT

+39 06 9480 3330 (9am-6pm, CET, Mon-Sat)

ES

+ 34 931786261 (9am-6pm, CET, Mon-Sat)

AU

+ 61 2 8310 9897 (11am-7pm, AEST, Mon-Fri)



FAQ

[avantree.com/support/ensemble](https://avantree.com/support/ensemble)

動画ガイド

[avantree.com/ensemble/video](https://avantree.com/ensemble/video)

製品登録

[avantree.com/product-registration](https://avantree.com/product-registration)

Manufacturer: Avatronics Limited  
Address: Luohu District, Shenzhen 518000 China

US Importer:  
Avantree Corporation  
San Jose, California 95119 USA

UK Importer:  
Avantree Limited  
Watford, WD180 0HQ UK



Servicer in Europe:  
Gizmex GmbH,  
Sternstr. 67, 40479 Dusseldorf, Germany  
Tel: 01 – 408 334 8648 [support@avantree.com](mailto:support@avantree.com)



Model No:BTHT-5150  
Dispose of the packaging and this product in accordance with the latest provisions.  
Z-PKQG-HT5150-BLK-V10