

Installation Instructions

PSE90 Flat Screen Electric Wall Mount

Design Highlights

- Quiet Smooth Action with Variable Speed Motion
- Full Cable Management
- Stylish Look and Finish
- Onboard Electronics
- Wide Range of Mounting Options



Thank you for choosing
futureautomation

PSE90 Flat Screen Electric Wall Mount



Caution
Warning



Beware of
Moving Parts



Danger
Electricity



Keep Hands
Clear

Safety Disclaimer

Important Safety Instructions

Explanation of graphical symbols

-(Electric Shock Symbol) = The lightning flash within an equilateral triangle is intended to alert you to the presence of un-insulated "dangerous voltage" within the products enclosure that may be of sufficient magnitude to constitute an electric shock to persons

-(Caution Symbol) = The exclamation point within an equilateral triangle is intended to alert you to the presence of important operating and maintenance (servicing) instructions in the literature accompanying the product

-(Tools Symbols) = The tools symbol within a coloured square are intended to highlight the required tools necessary for correct and safe installation of the product. These are intended as a guide only, and it is at the installer's discretion as to which tools are used.

WARNING: RISK OF ELECTRIC SHOCK, ONLY AUTHORIZED INSTALLERS TO OPEN THE POWER CONTROL BOX.

WARNING: To reduce the risk of fire or electric shock, do not expose electrical parts to rain or moisture, unless the product has been specifically designed to do so.

WARNING: Failure to provide adequate structural strengthening, prior to installation can result in serious personal injury or damage to the equipment. It is the installer's responsibility to ensure the structure to which the component is affixed can support the four times the weight of the component.

WARNING: Do not exceed the weight capacity. This can result in serious personal injury or damage to the equipment. It is the installer's responsibility to ensure that the total combined weight of all attached components does not exceed that of the maximum figure stated.

WARNING: Failure to provide adequate structural strength for this component can result in serious personal injury or damage to equipment! It is the installer's responsibility to make sure the structure to which this component is attached can support five times the combined weight of all equipment. Reinforce the structure as required before installing the component.

Warnings:

1. Read all technical instructions fully before installation and use. It is the installer's responsibility to ensure that all documentation is passed on to the end user and read fully before operation.
2. Keep all documentation.
3. Heed all warnings.
4. Follow all technical specifications and instructions during installation.
5. Do not use near water unless the product has been specifically designed to do so.
6. Clean only with a dry cloth.
7. Do not defeat the purpose of the polarized or grounding type plug. A polarized plug has two blades, one wider than the other. A grounding type plug has two blades and a grounding prong. The wide blade or third prong are provided for your safety. If the provided plug does not fit your outlet, consult an electrician or contact the manufacturer.
8. Protect the power cord from being walked on or pinched, particularly at plugs, convenience receptacles, and the point where the exit from the apparatus.
9. Unplug the apparatus during lightning storms or when unused for long periods of time.
10. Only use attachments/accessories specified by the manufacturer.
11. Refer all servicing to qualified personnel. Servicing is required regularly on an annual basis, when the apparatus is damaged in any way, liquid has been spilled or objects have fallen into the apparatus, the apparatus has been exposed to rain or moisture, does not operate normally, or has been dropped.
12. To completely disconnect the apparatus from the AC mains, disconnect the power cord plug from the AC receptacle on the power control box.
13. To prevent overheating, do not cover the apparatus. Install in accordance with the instructions.
14. UK, Ireland and Hong Kong only – The power cord is supplied with a 13A plug having an earthing pin. The apparatus is earthed and this pin is not required for safety, merely to operate the safety shutter of mains outlet.
15. No naked flames such as lit candles should be placed on the unit.
16. Observe and follow the local regulations when disposing of batteries.
17. Do not expose the unit to dripping or splashing fluids.
18. Do not place objects filled with liquid, such as vases, on the unit.
19. Do not expose the batteries to excessive heat such as sunshine, fire or the like.
20. For all mounted apparatus, the apparatus should be installed on solid wood, bricks, concrete or solid wood columns and battens.
21. Always turn off power at source before putting on or taking off parts and cleaning.
22. Do not use outdoors unless marked for outdoor use.
23. Exceeding the weight capacity can result in serious personal injury or damage to equipment.

Future Sound & Vision trading as Future Automation intend to make this and all documentation as accurate as possible. However, Future Automation makes no claim that the information contained herein covers all details, conditions or variations, nor does it provide for every possible contingency in connection with the installation or use of this product. The information contained in this document is subject to change without prior notice or obligation of any kind. Future Automation makes no representation of warranty, expressed or implied, regarding the information contained herein. Future Automation assumes no responsibility for accuracy, completeness or sufficiency of the information contained in this document.

PSE90 Flat Screen Electric Wall Mount

Contents	Page
Introduction	
Safety Information	1
Contents	2
Contents	3
Tool Indicator Icons	3
Installation	
Parts List	4
Package Contents	4
Stage 1	
Screen Fitment	5
Before You Start Check	5
Stage 2	
Vertical Height Alignment	6
Stage 3	
Opening The Mechanism Prior To Fitting	7
Stage 4	
Fitting The Mechanism To The Wall	8
Stage 5	
Removing The Side Panel & Cable Management	9
Stage 6	
Mounting The Screen	10
Stage 7	
Final Checks & Set Up	11
Electrical Connections	
Contact Closure	12
RS232	13
Operation Details	13
Operations	
IR Control	14
IR Operation Buttons	14
Changing Batteries	14
Storing Positions	14
Trouble Shooting	15
Technical Overview	16

PSE90 Flat Screen Electric Wall Mount

Tool Indicator Icons

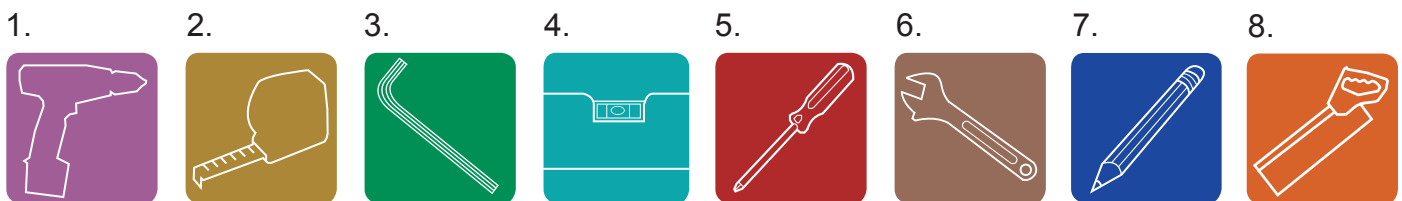

1. - Drill

2. - Tape measure

3. - Allen Keys

4. - Spirit Level

5. - Screwdrivers

6. - Spanners

7. - Pencil

8. - Saw

Product Warranty

This product carries a warranty that covers the cost of labour and spare parts incurred by any defects in materials and workmanship under normal use during a two year period from date of purchase. Support for any problems that are not hardware faults are excluded from the warranty entitlement. This warranty does not affect your statutory consumer rights.

The following is excluded from warranty service:

- Malfunctioning caused by misuse or damage, accidental or otherwise, or service modification by persons not authorised by Future Automation, or the use of any non Future Automation supplied parts;
- Any electrical, or other environmental work external to your Future Automation mechanism including power cuts, surges or lightning strikes;
- Additional items not supplied by Future Automation although they may have been supplied together by the retailer;
- Any 3rd party software products controlling your mechanism;
- Any transfer of ownership. Warranty is provided only to the initial purchaser;
- Compensation for loss of use of the product, and consequential loss of any kind;
- Use of the product over the specified weight capacity;
- Any damage to products during transit that is not checked and notified as "unchecked" or "damaged" upon receipt of delivery.

Any part of your system that needs to be replaced during a warranty repair becomes the property of Future Automation.

PSE90 Flat Screen Electric Wall Mount

Package Contents

- 1 - Mechanism
- 1.1 - Screen Mount Plate
- 1.2 - Wall Mount Plate
- 1.3 - Mechanism Cover
- 1.4 - Link Arm
- 2 - IR Remote Control

Not Shown On Page

- 3 - x2 AAA Batteries
- 4 - Multi Pack Of Nut, Bolts & Washers
- 5 - Mains Power & Other Leads

(Your pack may also contain a custom adapter if your screen is not VESA compatible)

Nuts & Bolts Multipack:

A range of nuts, bolts, washers and spacers to help add in the mounting for your screen

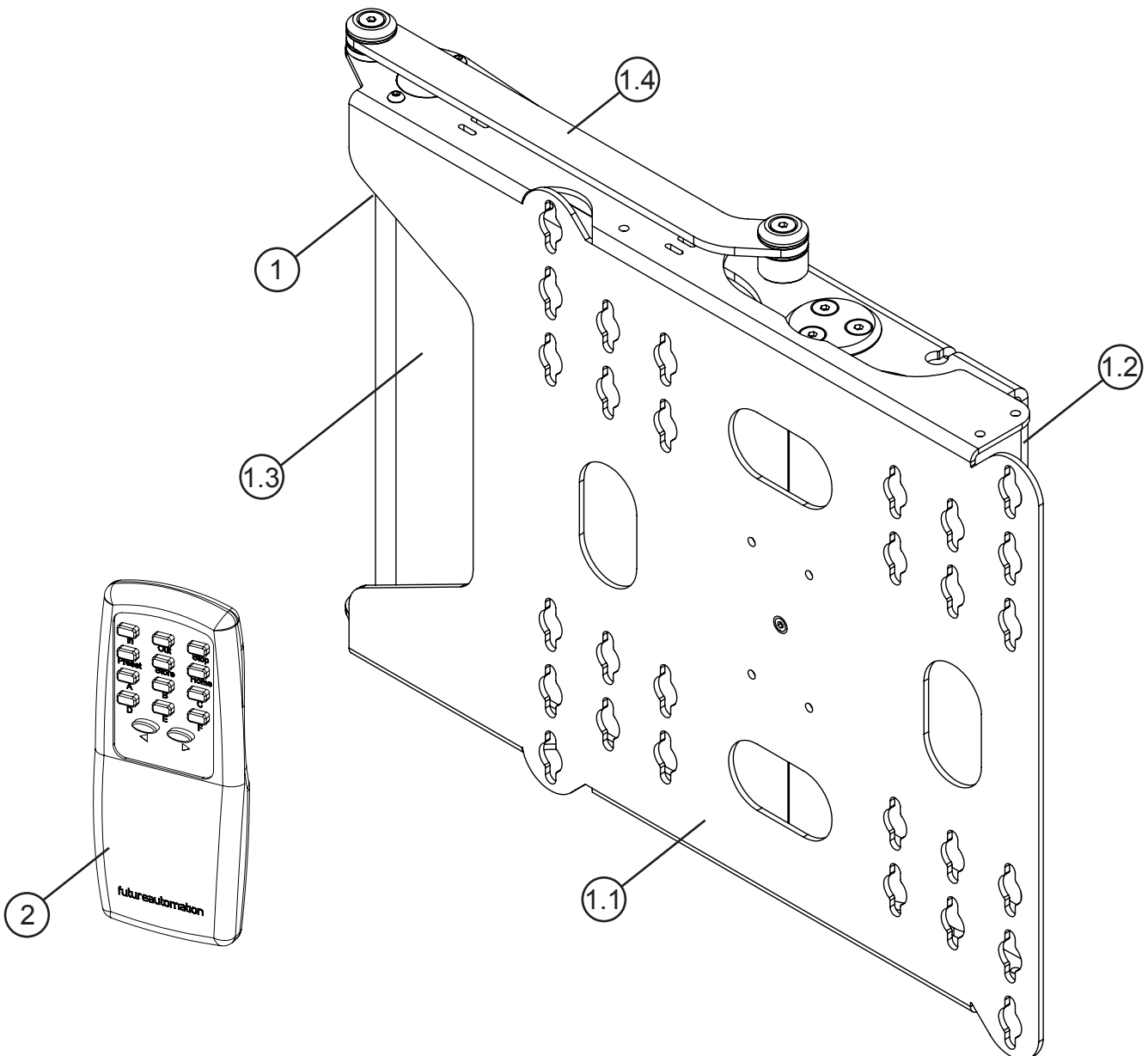

PSE90 Flat Screen Electric Wall Mount



Screen fitment

Before you start, check the following:

- The product is in good condition
- No damage to any parts
- Wiring is all secure
- The unit is in the closed position
- When testing the product make sure to run in the operating position

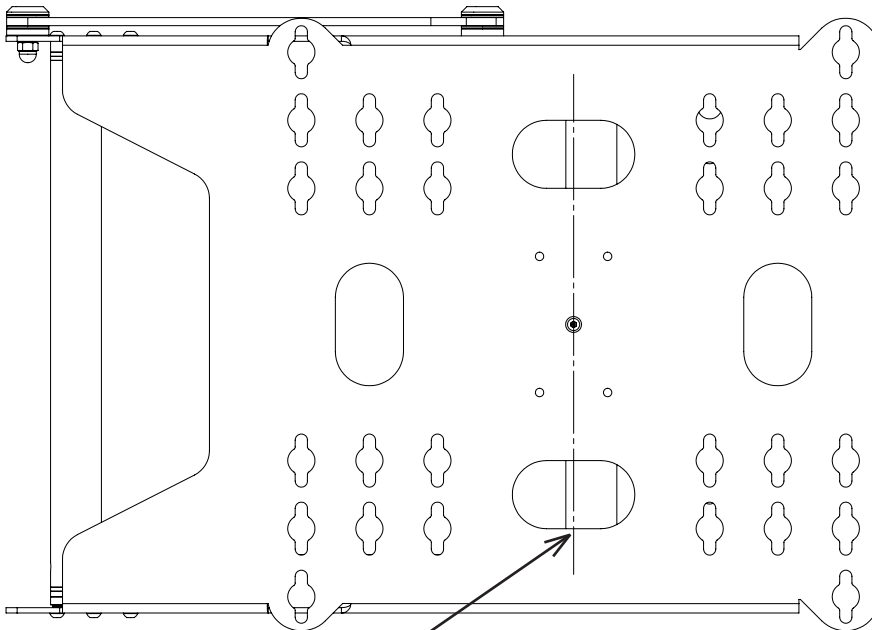
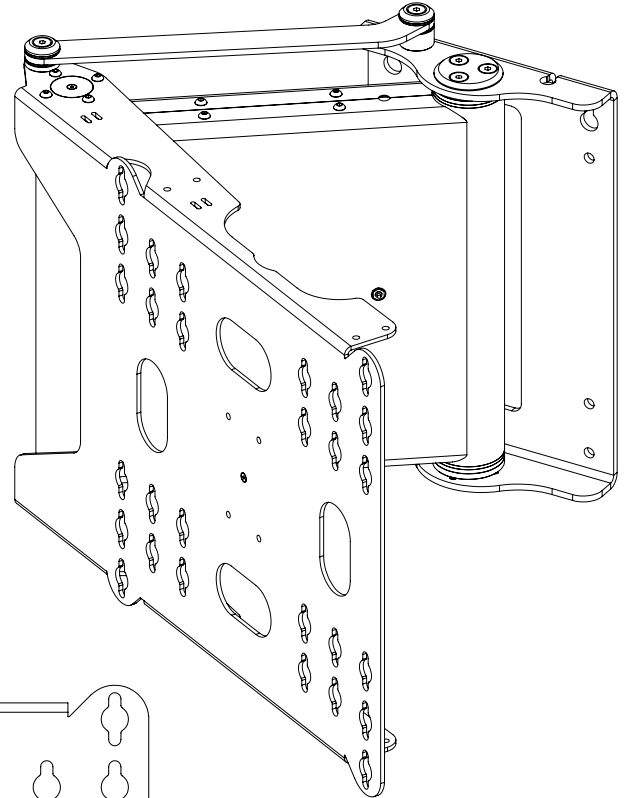

Screen symmetrical about this centre line

If your screen is not a VESA compatible, then a custom adapter will need to be added to the PSE90 bracket to suit your screen. Further instructions relating to any custom mount will be included with the custom adapter.

When fitting the screen to the mechanism, make sure that the centre of any adaptor plate is in line with the centre hole on the mechanism.

PSE90 Flat Screen Electric Wall Mount



Vertical height alignment

Carefully place the screen face down on the floor and then fix the PSE90 to the screen using the fixings supplied

Measure the distance from the top of the screen down to the top mounting hole on the wall plate. From this measurement it is possible to determine where to drill the holes in the wall

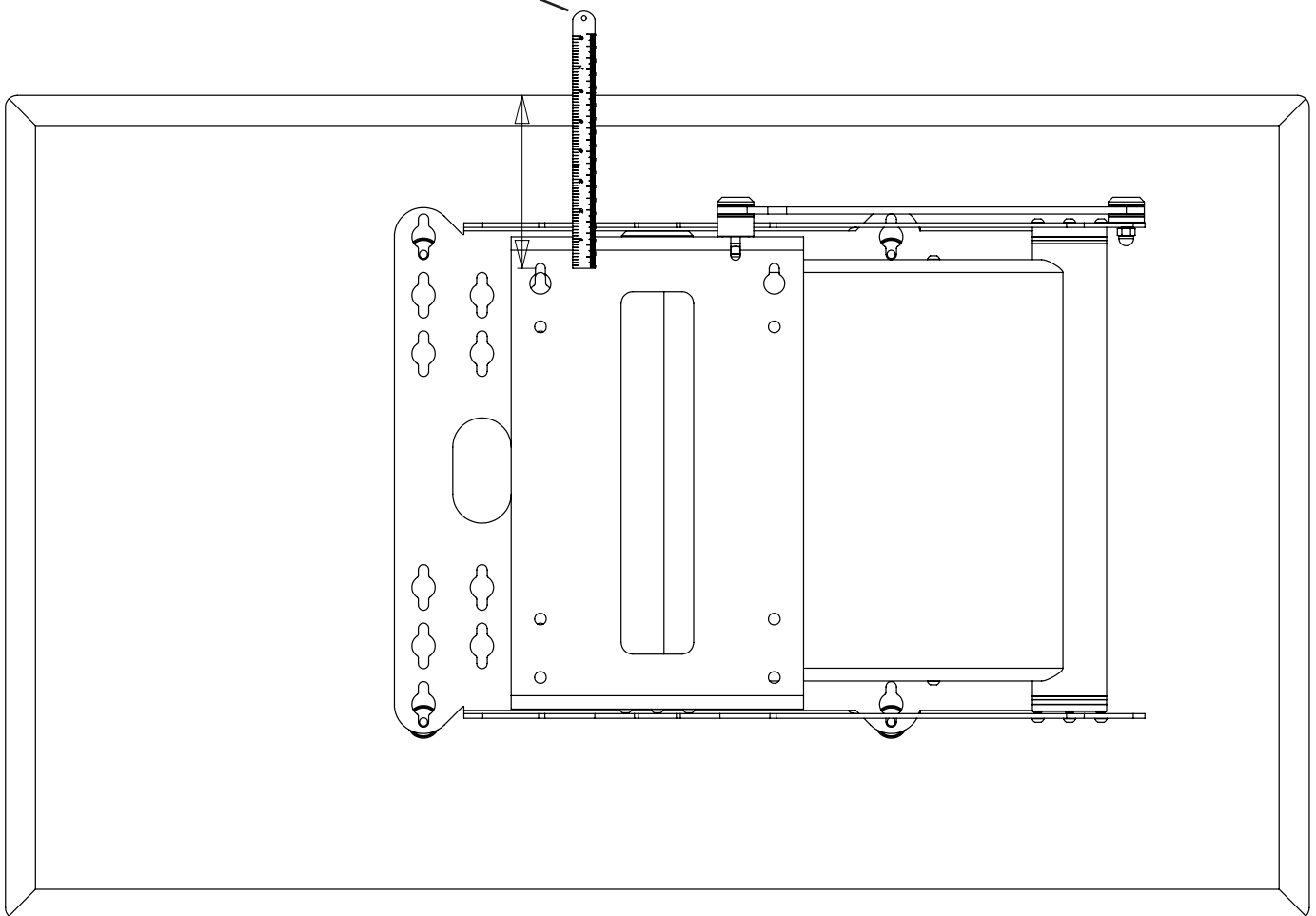

Remove screen from the mount before attaching the mechanism to the wall

PSE90 Flat Screen Electric Wall Mount

Opening the mechanism prior to fitting

Before fitting the mechanism to the wall, it will need to be opened to allow access to the wall plate. This must be done as per these instructions to avoid damage to the mechanism.

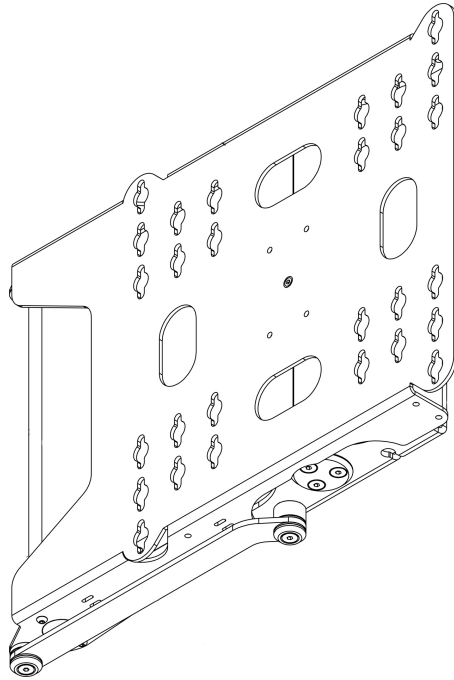

1 - Hold the PSE90 by the wall plate, upside down (link arm underneath as shown) on a soft, non-abrasive surface that is free from any obstructions.

2 - Make sure the power is connected and press the "Home" button on the remote control. This will open the bracket to 45 degrees.

3 - Remove the power and turn the PSE90 the correct way up, before fitting onto the wall as shown on the next page.

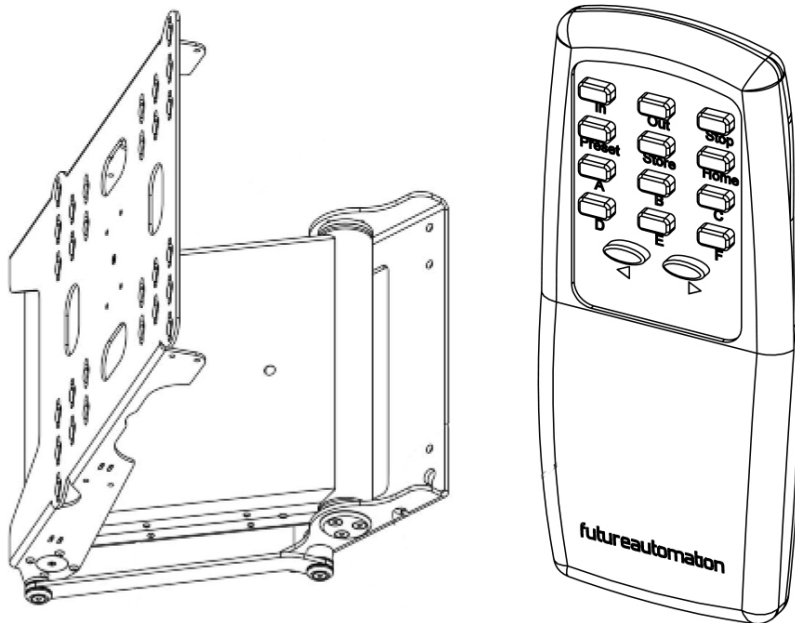

PSE90 Flat Screen Electric Wall Mount



Fitting the mechanism to the wall

Once you have decided on the location of your screen you can fix the wall plate to the wall.

1 - Fix the top 2 screws into the wall. Keyhole details are 200mm apart, symmetrical about screen centre

2 - Hang the mechanism on the screws using the key hole detail at the top of the wall mounting plate

3 - Continue to secure the other 6 fixings in place

Step ①

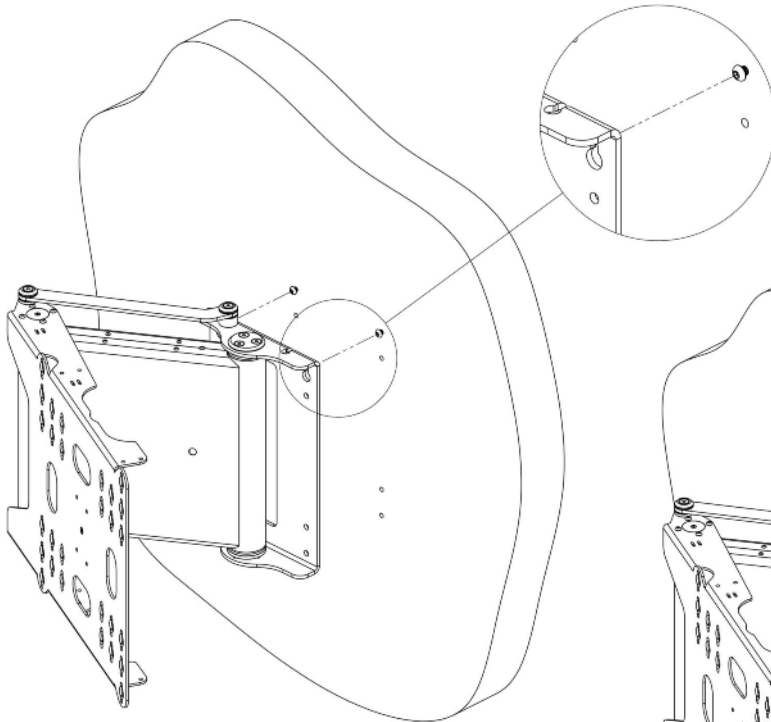

Step ②

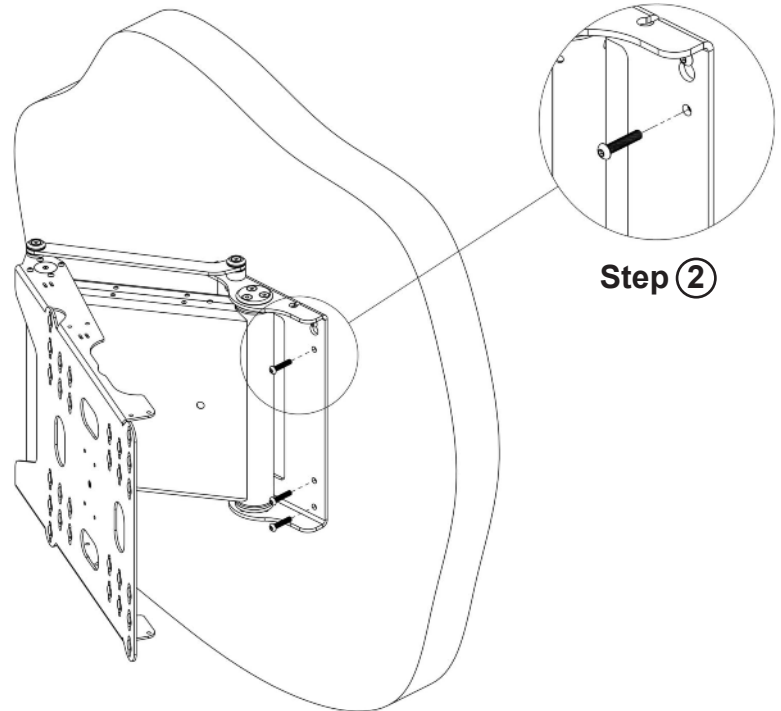

Fixings

- Fix through one of the top holes first
- Using the wall plate as a template, mark the other holes before drilling into the wall
- Make sure a spirit level is used at all times to ensure mechanism is always level



It is the installers responsibility to choose the appropriate fixings when attaching to the wall and to make sure the mechanism is safe and secure.

Make sure the wall which the PSE90 is being mounted to is structurally suitable

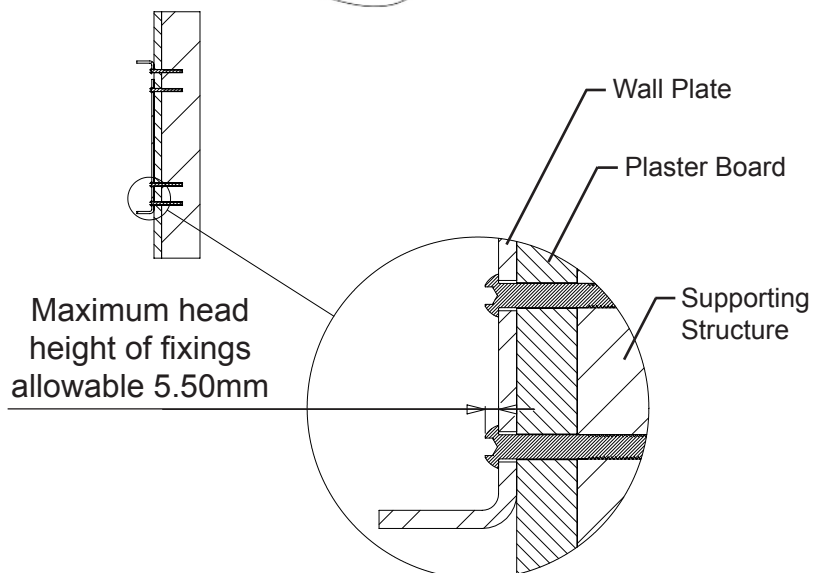

PSE90 Flat Screen Electric Wall Mount



Removing side panel & cable management

Before fitting the screen run the cables through the mechanism. Take off the side panel as shown by removing the 4 bolts, 2 top and 2 bottom, that hold it in place.



Disconnect the mains power before removing the panels.

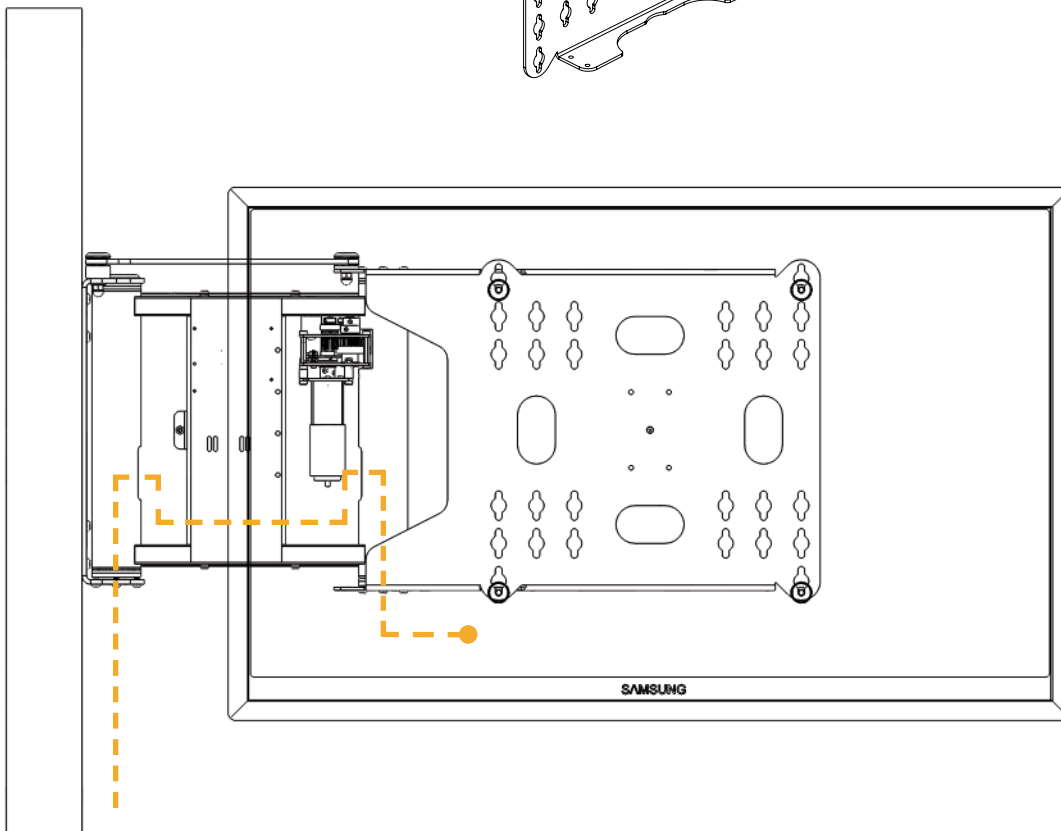
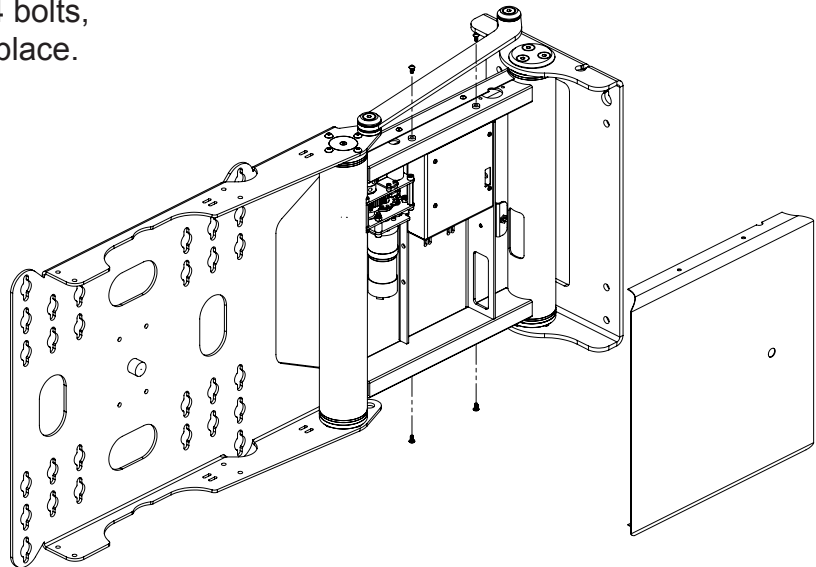

Cable management

Now you can feed the cables through the inner tube, along the lower strut and back down the outer tube. Keep all the cables well secured. Use as low profile cables as possible



Replace side panels before using the PSE90

PSE90 Flat Screen Electric Wall Mount



Mounting the screen

Attach the screen to the mounting plate using the appropriate fixings found in the fixtures pack.

It may be necessary with some screens to use spacers to provide clearance for AV cables at the rear

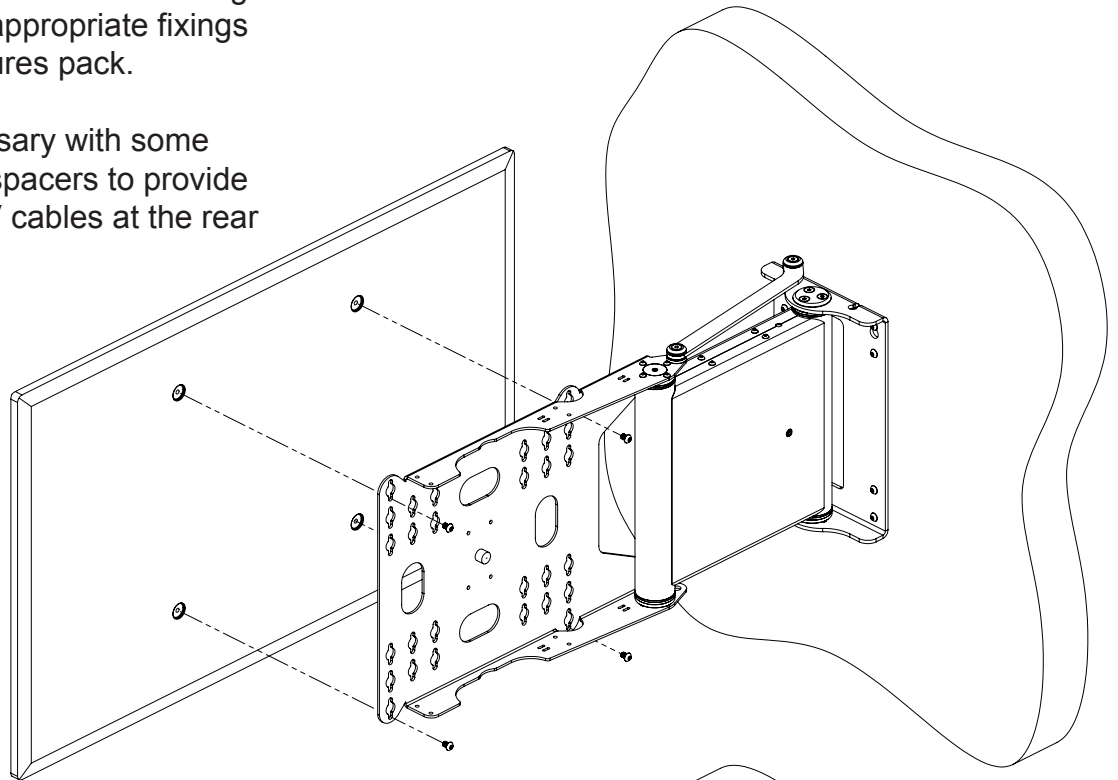

Make sure the mechanism is out when mounting the screen

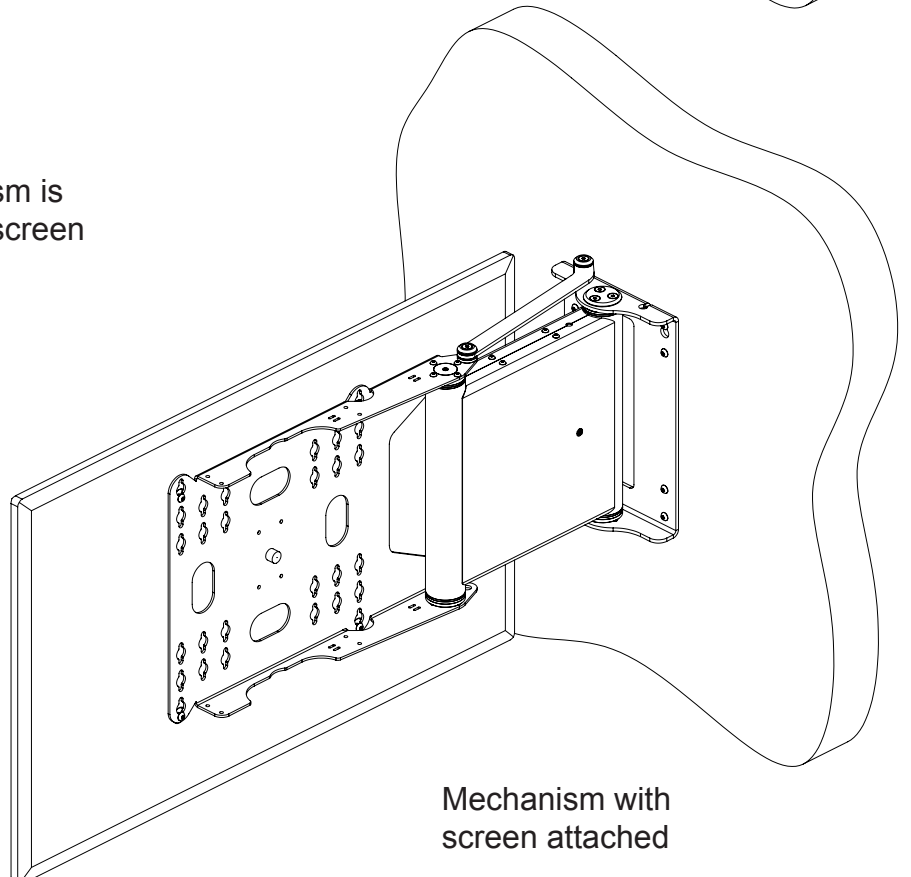

Mechanism with screen attached

PSE90 Flat Screen Electric Wall Mount



Final Checks & Set Up

- Make sure that both side panels are fitted securely in place
- Nothing is obstructing the movement of the mechanism or screen
- Product is square and level on the wall
- The product condition is good and all the wiring is neatly organised

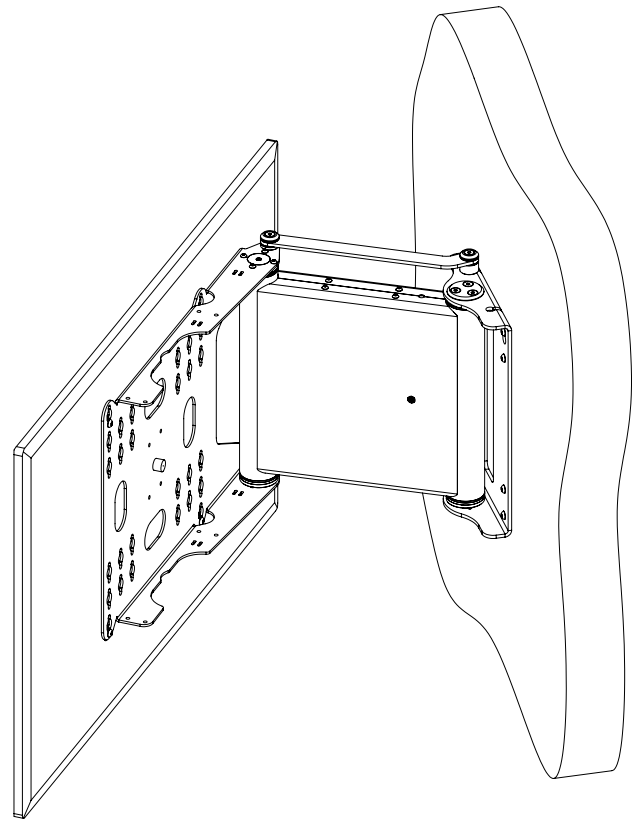

Installation: Stage 7

Bracket movement and preset options:

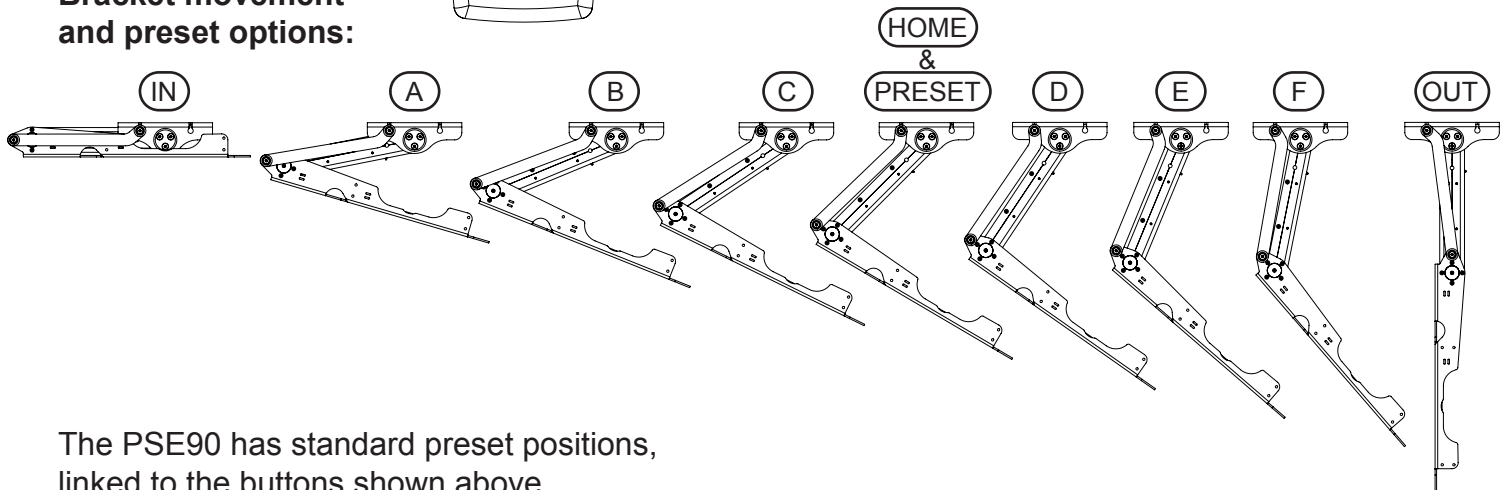
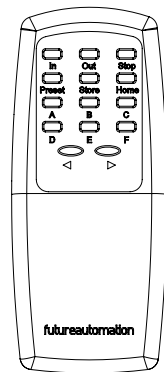

The PSE90 has standard preset positions, linked to the buttons shown above.

The preset options are not active until the mechanism has gone fully OUT and IN.

If the mechanism is moving and the power is cut, to revise ALL positions the mechanism needs to go back to the IN position, after which the previously stored programmed positions will be retained.

Storing new locations - Press STOP in the desired position then press STORE and you'll have a 2 second window to press HOME, PRESET or buttons A-F to save that position to that particular button. Multiple custom positions can be stored.

PSE90 Flat Screen Electric Wall Mount



Contact Closure

Use an RJ45 connector in the CCI socket on the control box to operate via contact closure

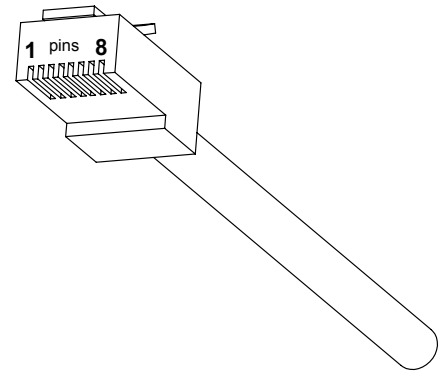

PIN	DESCRIPTION	ACTION	WIRE / CABLE	
			568A	568B
1	12V SUPPLY	12V SUPPLY - CURRENT LIMITED	W/G	W/O
2	12V LATCH	When 12V attached, device will go OUT to PRESET position. When 12V removed, device will go IN.	G	O
3	GROUND	GROUND	W/O	W/G
4		PIN 4 NOT USED	BL	BL
5	DEVICE LATCH	Short to GROUND (pin 3), device will go OUT to PRESET position, remove short device will go IN.	W/BL	W/BL
6	DEVICE STOP	Momentary short to GROUND (pin 3), stops device in current position.	O	G
7	DEVICE OUT	Momentary short to GROUND (pin 3), makes device go OUT.	W/BR	W/BR
8	DEVICE IN	Momentary short to GROUND (pin 3), makes device go IN.	BR	BR

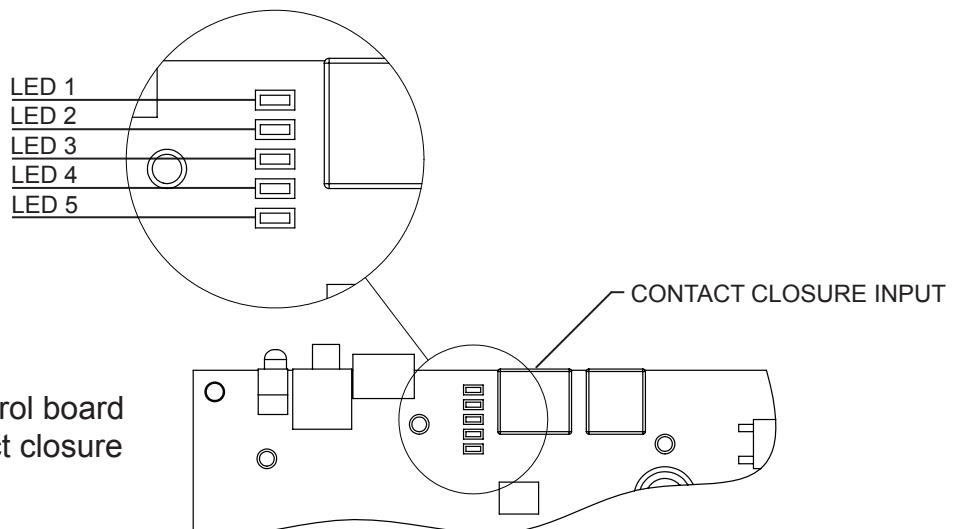

NOTE:
Earlier versions of the control board may not have these contact closure LED indicators.

PSE90 Flat Screen Electric Wall Mount



Details

Baud rate: 9600
 Stop bit: 1
 Parity: None
 Databits: 8

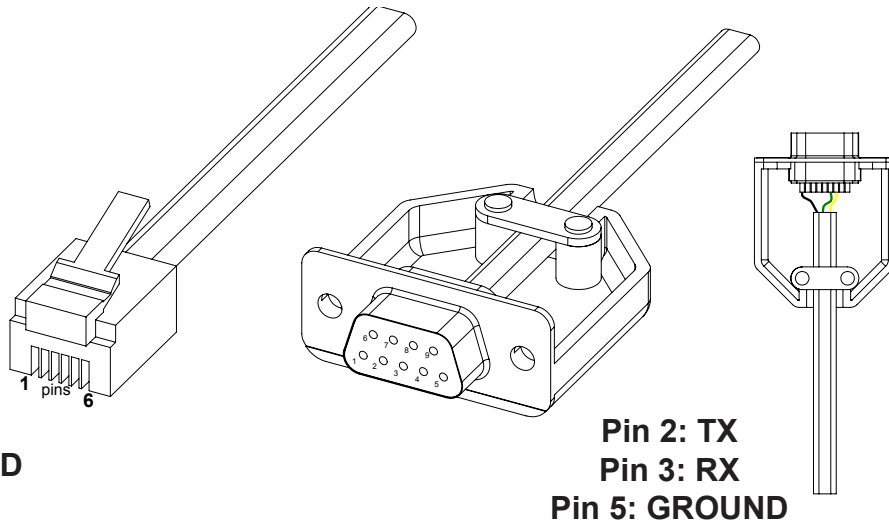

Pin 1: RX
Pin 6 : TX
Pin 3 & 4: GROUND

Pin 2: TX
Pin 3: RX
Pin 5: GROUND

RS232

- Use an RJ25 connector in the socket marked RS232 on the control box to operate using RS232



IMPORTANT

Ensure protocol is entered exactly as written, including Carriage Return ↵ (Enter / ASCII 13). After pressing STORE you have a 2 second window to select your save button, after 2 seconds the command is void.

RJ25		9 PIN D
PIN 1: RX	TO	PIN 2: TX
PIN 6: TX	TO	PIN 3: RX
PIN 3: GROUND	TO	PIN 5: GROUND
PIN 4: GROUND	TO	PIN 5: GROUND

COMMAND		ACTION
Step 1	Step 2	
fa_in ↵		Device IN
fa_out ↵		Device OUT
fa_stop ↵		Device STOP
fa_store ↵	fa_(preset, home,a-f) ↵	Store memory position
fa_preset ↵		Device to stored memory position

Operation Details

DC1

Low voltage power output for motor drive.LED's to show operation of limit switches and positional counters

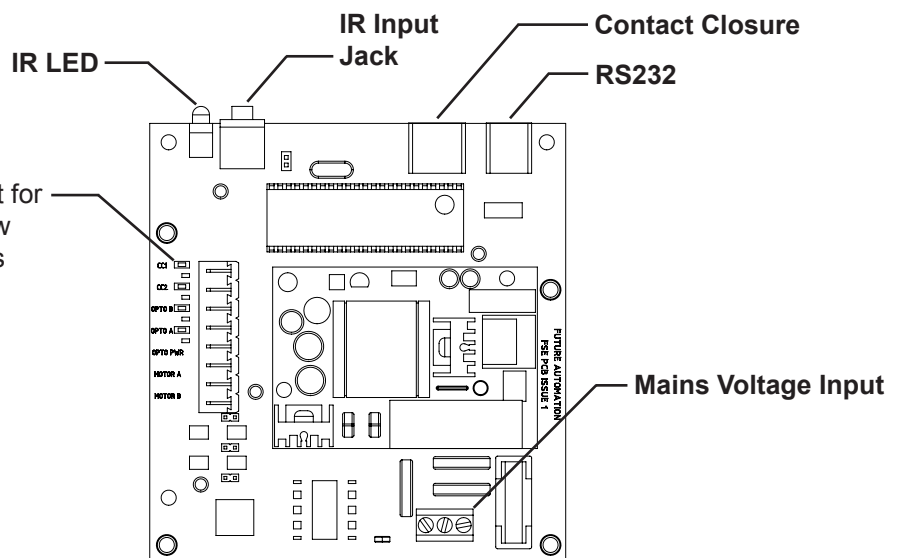

PSE90 Flat Screen Electric Wall Mount



Note

Only buttons indicated are functional with the product

Operation buttons for the IR remote

In - Brings the bracket fully in parallel to the wall

Preset - Brings the bracket back out to the stored position

Store and then Preset - Stores the current location into the PSE90 memory

Out - Brings the bracket fully out 90° to the wall

Stop - Will stop the operation at any position

Store and then A,B,C,D,E,F - can also be stored as preset positions

Replacing batteries

Future Automation IR Remote

Controller needs x2 AAA batteries which are provided within the packaging

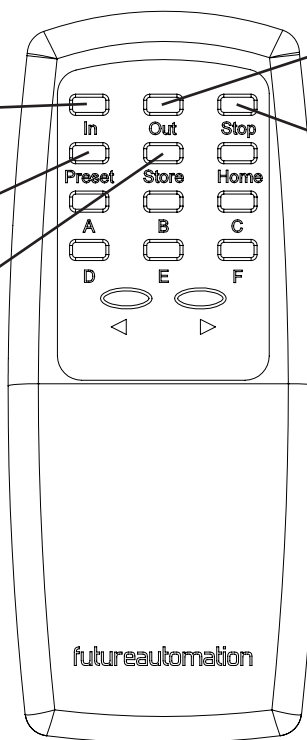
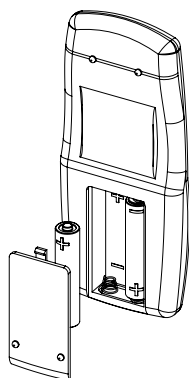

futureautomation

Storing favourite position

Store your favourite viewing position, which can be learned over and over again

① Press **IN** before starting

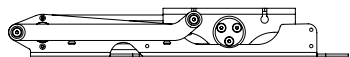

⑤ Press **PRESET** to make the bracket come out to the stored position

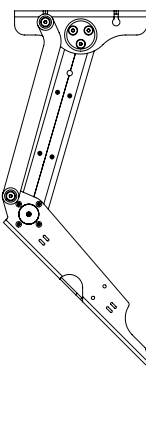

② Press **STOP** to stop at desired position
③ Then press **STORE** and then **PRESET** to learn that position

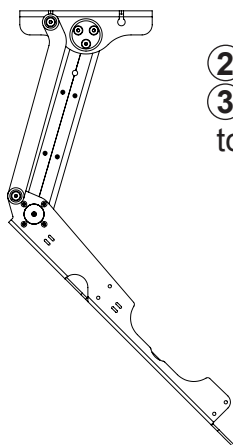

④ Then return to the **IN** position

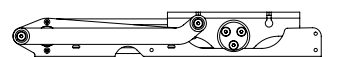

PSE90 Flat Screen Electric Wall Mount



Wall Mount M-PSE90 - Trouble shooting

For information & technical support on our products
please refer to the relevant web site or phone number -

General Contact

info@futureautomation.co.uk

+44 (0)1438 833577

US Contact

info@futureautomation.net

+1 (603) 742 9181

PSE90 Flat Screen Electric Wall Mount



A general technical overview of the PSE90 flat screen electric wall mount

	PSE90
Product Dimensions (W,D,H When Closed)	580x95x455mm [22.8x3.7x17.9"]
Weight (Kg)	18Kg [39.7lb]
Power Consumption	Max 120W
Power Consumption On Standby	3W
Lifting Capacity (Kg)	100Kg [220.5lb]
Standard Colour	Black
Max Rotation	90°
Max Television Size (Width)	1400mm [55.1"]
Control	IR Remote, RF Remote, Contact Closure & RS232
Power Supply	240V or 110V
Control Of 3rd Party Product	No
Output Power Supply	No
Shipping Details	
Dimensions (W,D,H)	700x600x200mm [27.6x23.6x7.9"]
Weight (Kg)	25Kg [55.1lb]

PSE90 Flat Screen Electric Wall Mount



Notes...



Future Automation

Unit 2 Kimpton Enterprise Park
Claggy Road
Kimpton
Hertfordshire
SG4 8HP
United Kingdom

Tel: +44 (0) 1438 833 577

Fax: +44 (0) 1438 833 565

Email: info@futureautomation.co.uk

www.futureautomation.co.uk